

DECEMBER 2019

EXAMINATION TIME TABLE  
PROGRAMME - F.E.(Sem I)(ALL BRANCHES) (Choice Based)old

Days and Dates	Time	Paper Code	Paper
Friday, November 15, 2019	10:30 a.m. to 01.30 p.m.	58601	Applied Mathematics – I.
Tuesday November 19, 2019	10:30 a.m. to 01.30 p.m.	58602	Engineering Mechanics.
Thursday, November 2 2019	10:30 a.m. to 01.30 p.m.	58603	Basic Electrical Engineering.
Monday November 25, 2019	10:30 a.m. to 12.30 p.m.	58604	Applied Chemistry – I.
Wednesday, November 27, 2019	10:30 a.m. to 12.30 p.m.	58605	Applied Physics – I.
Friday, November 29, 2019	10:30 a.m. to 12.30 p.m.	58606	Environmental Studies (EVS).

(Time: 3 hours)

Total Marks: 80

- N.B. (1) Question no. 1 is Compulsory  
(2) Solve any three from the remaining.

- Q.1) a) Prove that  $(1 + i\sqrt{3})^8 + (1 - i\sqrt{3})^8 = -2^8$  (3)
- b) If  $A = \frac{1}{3} \begin{pmatrix} 1 & 2 & a \\ 2 & 1 & b \\ 2 & -2 & c \end{pmatrix}$  is orthogonal find a,b,c. (3)
- c)  $z^3 + xy - y^2z = 6$  find  $\frac{\partial z}{\partial x}$  and  $\frac{\partial z}{\partial y}$  where z is an implicit function of x and y. (3)
- d) If  $u = e^x \cos y, v = e^x \sin y$  find  $\frac{\partial(u,v)}{\partial(x,y)}$ . (3)
- e) Find the  $n^{th}$  derivative of  $y = \frac{x^2+4x+1}{x^3+2x^2-x-2}$  (4)
- f) Find a,b if  $\lim_{x \rightarrow 0} \frac{a \sinh x + b \cosh x}{x^3} = \frac{5}{3}$  by L'Hospital's Rule. (4)

- Q.2) a) Find the roots common to  $x^4 + 1 = 0$  and  $x^6 - i = 0$  (6)
- b) If  $y = \sin^{-1} x$  Prove That  
 $(1 - x^2)y_{n+2} - (2n + 1)xy_{n+1} - n^2y_n = 0$  also find  $y_9(0)$  (6)
- c) Discuss the maxima and minima of  
 $f(x, y) = x^3 + 3xy^2 - 15x^2 - 15y^2 + 72x$  (8)  
Hence find maximum and minimum value of  $f(x, y)$ .

- Q.3) a) Find the values of k for which the equations  
 $x + y + z = 1, x + 2y + 3z = k, x + 5y + 9z = k^2$  have a solution,  
solve them for these values of k. (6)
- b) If  $x = \sqrt{vw}, y = \sqrt{wu}, z = \sqrt{uv}$ , Prove that  
 $x \frac{\partial \phi}{\partial x} + y \frac{\partial \phi}{\partial y} + z \frac{\partial \phi}{\partial z} = u \frac{\partial \phi}{\partial u} + v \frac{\partial \phi}{\partial v} + w \frac{\partial \phi}{\partial w}$   
where  $\phi$  is the function of x,y,z. (6)
- c) If  $\tan(\alpha + i\beta) = \cos\theta + i\sin\theta$  Prove that  
 $\alpha = \left(\frac{n\pi}{2} + \frac{\pi}{4}\right) & \beta = \frac{1}{2} \log \tan \left(\frac{\pi}{4} + \frac{\theta}{2}\right)$ . (8)

- Q.4) a) If  $z = e^{x/y} + \log(x^3 + y^3 - x^2y - xy^2)$ , Find the value of  
 $x \frac{\partial z}{\partial x} + y \frac{\partial z}{\partial y} + x^2 \frac{\partial^2 z}{\partial x^2} + 2xy \frac{\partial^2 z}{\partial x \partial y} + y^2 \frac{\partial^2 z}{\partial y^2}$ . (6)
- b) Using encoding matrix  $\begin{bmatrix} 1 & 1 \\ 0 & 1 \end{bmatrix}$  encode and decode the message  
NOW\*STUDY (6)
- C) Solve the following equations by Gauss Jacobi's Iteration method  
 $15x + 2y + z = 18, 2x + 20y - 3z = 19, 3x - 6y + 25z = 22$  (8)

Q.5) a) Prove that the general value of  $(1 + itana)^{-i}$  is  $e^{2m\pi+\alpha}[\cos(\log\cos\alpha) + isin(\log\cos\alpha)]$  (6)

b) State and Prove Eulers Theorem for function of Three Variables. (6)

c) Expand  $x^5 - x^4 + x^3 - x^2 + x - 1$  in powers of  $(x - 1)$  and hence find  $f\left(\frac{11}{10}\right), f(0.99)$ . (8)

Q.6) a) Prove that:

$$\sinh^7 x = \frac{1}{64}(\sinh 7x - 7\sinh 5x + 21\sinh 3x - 35\sinh x) \quad (6)$$

b) Find nonsingular matrices P and Q such that PAQ is in Normal form.

also find Rank of A, where  $A = \begin{bmatrix} 2 & 1 & 4 \\ 3 & 2 & 2 \\ 7 & 4 & 10 \\ 1 & 0 & 6 \end{bmatrix}$ . (6)

c) Using Newton Raphson Method find an iterative formula for  $\sqrt[5]{N}$  where N is positive number, Hence find  $\sqrt[5]{35}$ . (8)

\*\*\*\*\*

(3 Hours)

Marks :80

- N.B. 1. Question No.1 is compulsory.  
 2. Answer any three questions from remaining questions.  
 3. Assume suitable data if required.  
 4. Figure to the right indicates full marks.  
 5. Take  $g = 9.81 \text{ m/s}^2$ .

Q.1 Attempt any four.

- a) A force of  $100 \text{ N}$  act at a point  $P (-2, 3, 5)\text{m}$  has its line of action passing through  $Q (10, 3, 4)\text{m}$ . Calculate the moment of force about origin.  
 b) A vertical lift of total mass  $750 \text{ kg}$  acquires an upward velocity of  $3 \text{ m/s}$  over a distance of  $4\text{m}$  moving with constant acceleration starting from rest. Calculate the tension in cable.  
 c) For the mechanism shown express the relation between forces  $F$  and  $P$  in terms of  $\theta$ , by principle of virtual work.

20

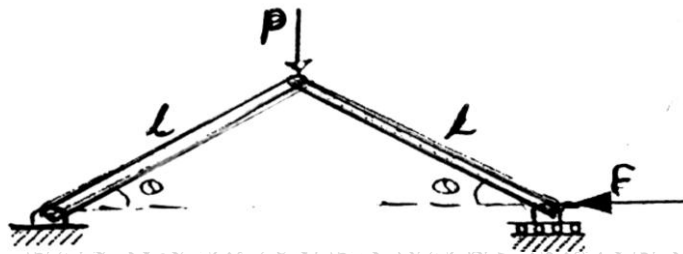

- d) A stone is released from top of the tower during the last second of its motion, it covers  $1/4^{\text{th}}$  of the height of the tower. Find the height of the tower.  
 e) A roller of weight  $500 \text{ N}$  has a radius of  $120 \text{ mm}$  and is pulled over a step at height  $60 \text{ mm}$  by a horizontal force  $P$ . Find magnitude of  $P$  to just start the roller over the step.

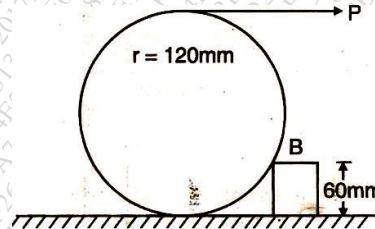

- f) Classify types of motion for rigid body with suitable examples.

Q.2 a) State the laws of dry friction.

- b) Find support reaction of the beam as shown in fig.

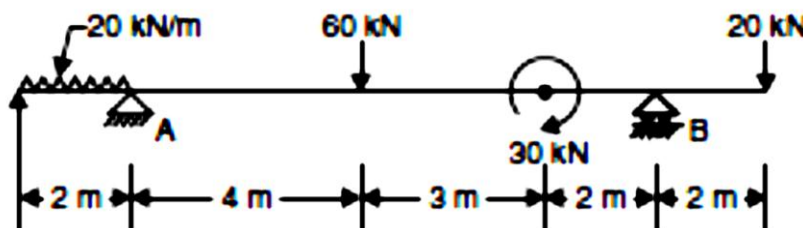

4

8

- c) Find the coordinates of the centroid of the shaded area with respect to the axes shown in Fig. 8

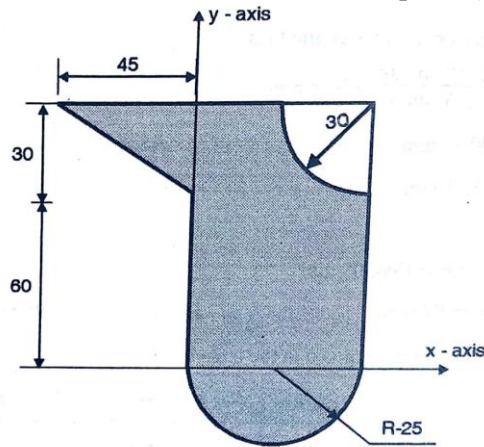

- Q.3 a) In Fig. The frictionless fixed drum, and coefficient of friction between other surfaces of contact is 0.3. Determine the minimum weight  $W$  to prevent downward motion of the 1000 N body. 8

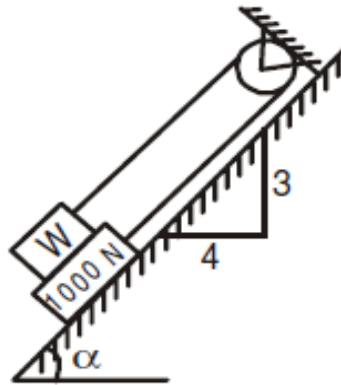

- b) Determine the resultant of the given force system as shown in fig. 6

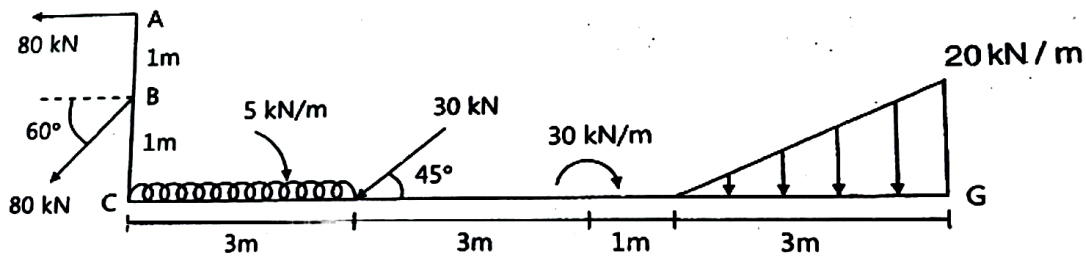

- c) An automobile starts from rest and travels on a straight path at  $2 \text{ m/s}^2$  for some time. After which it decelerates at  $1 \text{ m/s}^2$ , till its comes to halt. If the distance covered is 300 m, find the maximum velocity of the automobile and the total time of travel. 6





- Q.6 a) Three identical spheres P, Q and R each of weight  $W$  are arranged on smooth inclined surface as shown in Fig. Determine the minimum angle  $\alpha$ , which will prevent the arrangement from collapsing. 8

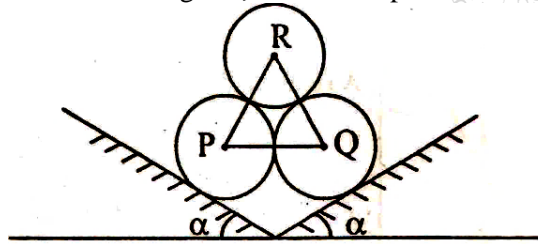

- b) The block of mass  $0.5 \text{ kg}$  moves within the smooth vertical slot. If it starts from rest, when the attached spring is in the upstretched position at A. determine constant vertical force  $F$  which must be applied to the cord, so that block attains a speed of  $2.5 \text{ m/s}$  when it reaches B. i.e.,  $S_B = 0.15 \text{ m}$ , neglect the mass of the cord, pulley and friction between cord and pulley. 6

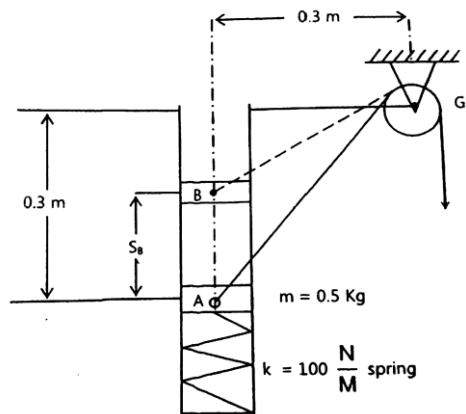

- c) A car is moving on a curve of radius  $300 \text{ m}$  at a speed of  $90 \text{ kmph}$ . The brakes are suddenly applied, causing speed to decrease at a constant rate of  $1.3 \text{ m/s}^2$ . Determine the total acceleration immediately after brakes have been applied. 6

- N. B. 1) Question No. 1 is **compulsory**.  
 2) Answer any 3 questions from the remaining 5 questions.  
 3) Assume suitable data wherever necessary.

- Q1 Solve the following 20  
 (a) Using source transformation, find I in the circuit shown.

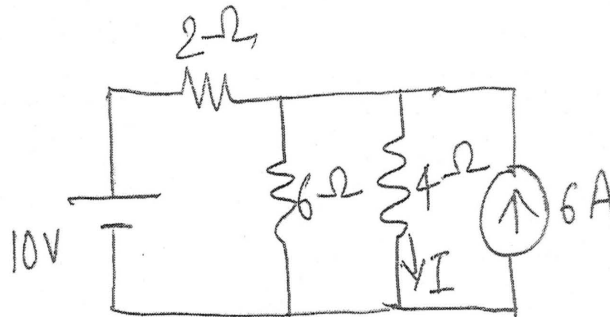

- (b) Derive emf equation for single phase transformer.  
 (c) Show that the sum of three phase emf's is zero in a three phase ac circuit.  
 (d) Compare series and parallel resonant circuit.
- Q2 (a) Coil A takes 2A at power factor of 0.8 lagging with an applied voltage of 10 V, second coil B takes 2 A with power factor of 0.7 lagging with applied voltage of 5V. What voltage will be required to produce a total current of 2 A with coil A and B in series. Find power factor in this case. 10
- (b) Draw no load phasor diagram of transformer and explain it. 6
- (c) Explain working principle of DC motor and DC generator. 4
- Q3 (a) Using Thevenin's Theorem, obtain the power drawn by 20Ω resistor in the network shown below. 10



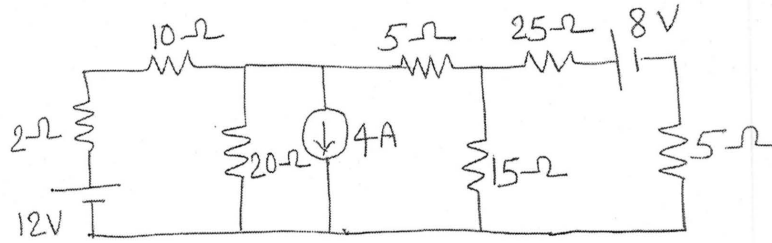

(b) In a balanced three phase circuit, the power is measured by two wattmeters, the ratio of wattmeter reading is 2:1. Determine the power factor of the system. 4

(c) Find the RMS value of the waveform. 6

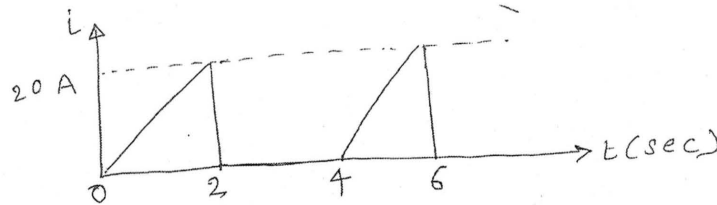

Q4 (a) A parallel circuit consists of  $2.5\mu\text{F}$  capacitor and a coil whose resistance and inductance are  $15\ \Omega$  and  $260\ \text{mH}$  respectively. Determine resonant frequency, Q factor of the circuit at resonance and dynamic impedance of the circuit. 7

(b) A balanced delta connected load has impedance of  $(14.151-j200)\ \Omega$  in each branch. Determine branch current, line current, total power taken if balanced three phase  $400\text{V}$ ,  $50\ \text{Hz}$  supply is used. How much power is absorbed in each branch of delta? 6

(c) Find the equivalent resistance between A & B. 7

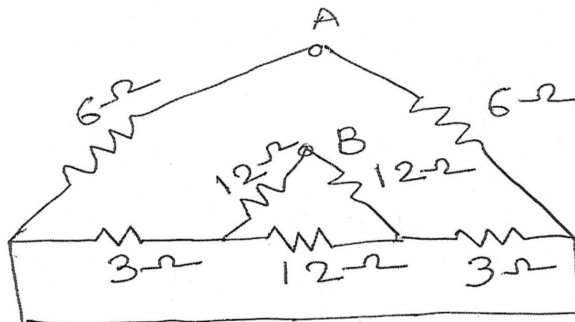

Q5 (a) Find the current through  $6\Omega$  resistance using Nodal analysis.

7

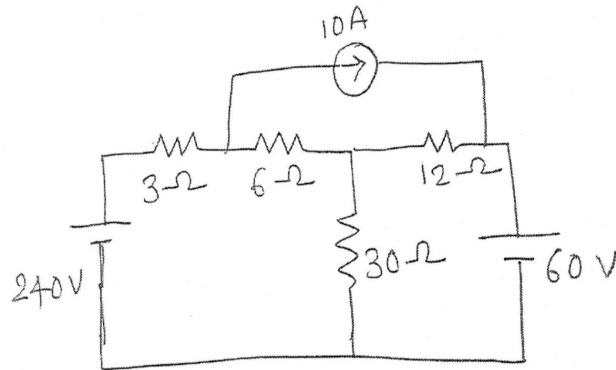

(b) Find  $I_1$  &  $I_2$ .

7

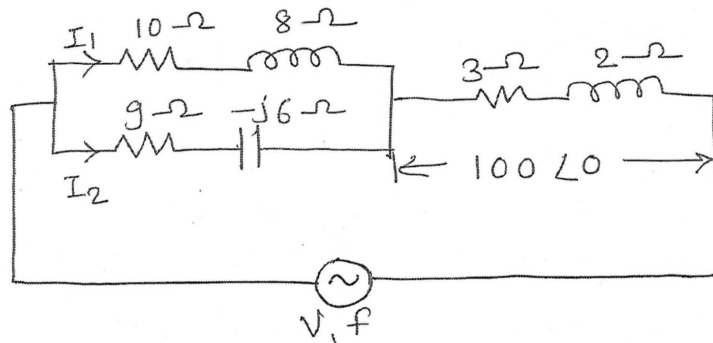

(c) A single phase 440/220V, 10 KVA, 50 Hz transformer has resistance of  $0.2\Omega$  and reactance of  $0.6\Omega$  on high voltage side. The corresponding values of low voltage side are  $0.04\Omega$  and  $0.014\Omega$ . Calculate the regulation on full load for 0.8 lagging power factor.

6

Q6 (a) Determine the relationship between phase and line voltage and current for star connected balanced load across a three phase balanced system.

6

(b) By mesh analysis, find V.

8

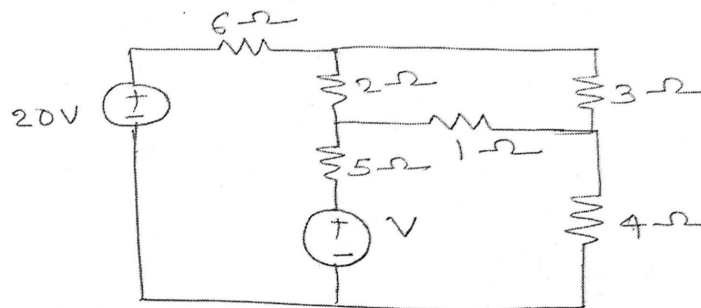

c) If  $v = 100 \sin 3t$ , determine branch current  $I_1$  &  $I_2$  with their phase angle and total current supplied by the source and its phase angle. 6

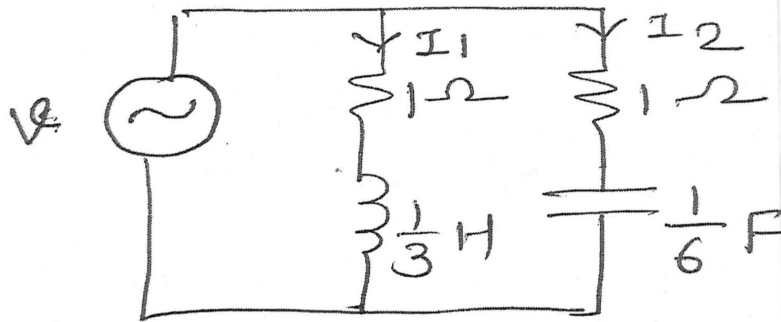

\*\*\*\*\*

(2 Hours)

Total Marks: 60

NB: 1. Question No.1 is compulsory.

2. Answer any three questions from remaining five.

3. All questions carry equal marks.

4. Atomic Weight: H=1, C=12, O=16, Ca=40, Na=23, Mg=24, Si=28, S=32, Cl=35.5, N=14, Al=27, K=39

**1. Solve any five.**

- (a) Write the applications of CNT's. 3
- (b) Distinguish between thermoplastic and thermosetting polymer. 3
- (c) Define viscosity and viscosity index. Discuss its significance. 3
- (d) What are conducting polymers? Explain with suitable examples. 3
- (e) Explain Gibb's phase rule. Define the terms involved in it. 3
- (f) Define BOD and COD. 3
- (g) Calculate Temporary and permanent hardness : 3

$$\text{Mg}(\text{HCO}_3)_2 = 73.8 \text{ mg/l}, \text{Ca}(\text{HCO}_3)_2 = 162.8 \text{ mg/l}, \text{MgCl}_2 = 95.8 \text{ mg/l}$$

$$\text{CaSO}_4 = 136 \text{ mg/l}$$

2. (a) 1g of  $\text{CaCO}_3$  was dissolved in 1 litre of distilled water. 50ml of this solution required 45ml of EDTA solution. 50 ml of hard water required 25 ml of EDTA. The same sample of water after boiling consumed 15 ml of EDTA. Calculate each type of hardness. 6
- (b) i) Write the role of plasticizers and stabilizers in the compounding of polymers. 3  
ii) What are Semi-solid lubricants? Under which conditions they are used. 2
- (c) What are CNT's? Explain chemical vapour deposition method of preparation of CNT's. 4
- 3.(a) What is fabrication of plastic ? Explain transfer moulding process with the help of neat labelled diagram. 6

- (b) i) Discuss the advantages and limitations of phase rule. 3  
 ii) What are fullerenes? Write important applications of fullerenes. 2
- (c) The hardness of 50,000 litres of water sample was removed by zeolite softener. The softness required 200 litres of NaCl solution containing 50gm/l. NaCl for regeneration. Calculate the hardness of water sample. 4
4. (a) Draw the diagram for demineralization process and write suitable reactions involved in the process. What are the advantages and disadvantages of the method. 6
- (b) i) 5 gms of an oil was saponified with 50 ml of 0.5 N alcoholic KOH. After refluxing for 2 hrs, the mixture was titrated by 15 ml of 0.5 N HCl. Find the saponification value of oil. 3  
 ii) What are the advantages of RCC over concrete? 2
- (c) Natural rubber requires vulcanization. Give reasons. With appropriate reactions explain how the drawbacks are overcome? 4
5. (a) Write preparation, properties and uses of following polymers: 6  
 i) PMMA ii) Silicone rubber
- (b) i) Define Chemical Oxygen Demand (COD). 25 ml of sewage water required 8.3 ml of 0.001M  $K_2Cr_2O_7$  for its complete oxidation. Calculate COD of this water sample. 3  
 ii) Mention the role of additives used in blended oils. 2
- (c) Draw and explain the phase diagram of Pb- Ag system. 4
6. (a) What are lubricants? Define Lubrication. Explain Hydrodynamic lubrication mechanism with neat diagram. 6
- (b) i) What is the Triple Point? At what conditions triple point exists in water system? 3  
 ii) Write a short note on reverse osmosis. 2
- (c) Explain wet process of preparing the Portland cement. 4



(2 Hours)

[Total Marks:60]

- N.B.: (1) Question. 1 is **compulsory**.  
 (2) Attempt any **three** questions from the remaining questions N0.2 to 6.  
 (3) **Assume** suitable **data** wherever required.  
 (4) **Figures** to the **right** indicate **marks**.

1. Attempt any **five** questions from the following- 15
- Calculate atomic packing fraction of HCP unit cell.
  - Express de-Broglie wavelength in various forms.
  - Draw the energy band diagram for p-n junction diode in forward and reverse bias condition.
  - Define: persistent current, critical temperature, critical magnetic field.
  - What is reverberation time? Explain its formula.
  - With the help of diagram state direct and inverse piezoelectric effect.
  - The resistivity of intrinsic material at room temperature is  $2 \times 10^{-4}$  Ohm-cm. If the mobility of electron is  $6 \text{ m}^2/\text{V-sec}$  and mobility of hole is  $0.2 \text{ m}^2/\text{V-sec}$ . Calculate its intrinsic carrier density.
- 2 (a) Arrive at the statement that electron can not survive inside the nucleus. 8  
 An electron has a speed of 300m/s with uncertainty of 0.01% . Find the accuracy in its position.
- (b) A sample of semiconductor is placed in uniform magnetic induction  $B$  with sample current  $I$  and thickness  $w$  then obtain the expression for (a) Hall voltage and (b) Hall coefficient. 7
- 3 (a) With neat diagram of unit cell explain the structure of diamond crystal. 8  
 (b) Explain variation of Fermi level with temperature in n-type semiconductor. 7  
 What is the probability of an electron being thermally excited to the conduction band in Si at  $30^\circ\text{C}$ . The band gap energy is 1.12eV ( $k=1.38 \times 10^{-23} \text{ J/K}$ )
- 4 (a) Distinguish between Type I and Type II superconductors. 5  
 (b) A class room has dimension of  $(20 \times 15 \times 10) \text{ m}^3$  ; the reverberation time is 3 sec. 5  
 Calculate the total absorption of its surfaces and average coefficient of absorption
- (c) How ultrasonic waves are produced using quartz crystal in an oscillator? 5
- 5 (a) Show that for an intrinsic semiconductor, the Fermi level lies half way between conduction and valence band. 5  
 (b) State and explain principle of SQUID and explain its working to determine the strength of magnetic field. 5  
 (c) The lowest energy of an electron trapped in a one dimensional box is  $3.2 \times 10^{-18} \text{ J}$ . Calculate the width of the box. Also calculate the next two energies in eV the particle can have? 5
- 6 (a) Define ligancy and critical radius ratio. Calculate critical radius ratio for ligancy 6. 5  
 (b) Obtain one dimensional time dependent Schrodinger equation 5  
 (c) Explain photovoltaic effect and write a note on solar cell. 5

\*\*\*\*\*

Time: 2 Hours

Marks: 60

N.B.:

- (1) Q.1 is compulsory. Attempt any three questions from Q.2 to Q.6.
- (2) Draw neat diagrams wherever necessary.
- (3) Figures to the right indicate full marks.

Q.1 Attempt **any five** from the following:-

15M

- a Define ecosystem. List out any four factors which disturb the energy balance in the ecosystem.
- b What is conventional source of energy? Mention any four drawbacks of conventional sources of energy.
- c What is photochemical smog? Give any four sources and any four bad effects of photochemical smog.
- d State any four sources responsible for water pollution of Ganga river. Mention any two ways for elimination of water pollution of Ganga river.
- e State any six functions of central pollution control board.
- f What is soil pollution? State any four side effects of pollution.
- g Mention any three social and economical aspects of sustainable development.

Q.2 Attempt the following:-

15M

- (a) What is industrial waste water? Mention any three sources and three bad effects of industrial waste water. Mention any two ways for removal of industrial waste water pollution. 5M
- (b) Give the principle, construction, working and schematic diagram of steam turbine power plant. Mention any two advantages and disadvantages of steam turbine power plant. 6M
- (c) What is the importance of environmental education? How does Biomass and energy flow are related in ecological pyramid? 4M

Q.3 Attempt the following:-

15M

- (a) Explain the case study of Fukushima disaster (March, 2011). 5M
- (b) What is environmental degradation? Mention the causes (any four) and bad effects (any four) of depletion of natural water resources. 5M

(c) What is green building? Explain the concepts and give any four objectives of Green building. 5M

Q.4 Attempt the following:- 15M

(a) Give the schematic diagram of venturi scrubber used for purification of air pollutants. 6M  
Give the principle, construction, any two advantages and disadvantages of venturi scrubber.

(b) What is indoor air pollution? Mention any four sources and four bad effects of indoor air pollution. 5M

(c) Write a short note on case study on Narmada Bachao Andolan. 4M

Q.5 Attempt the following:- 15M

(a) Explain the concept of flat plate collector with the help of its principle, construction, working, advantages (any two) and disadvantages (any two). 6M

(b) Define noise pollution. Mention any three sources and three adverse effects of noise pollution. 4M

(c) What do you mean by Solid waste? What are the different sources (any four) responsible for the solid waste? Explain composting in brief. 5M

Q.6 Attempt the following:- 15M

(a) Give the neat and labeled diagram for photovoltaic cell. Give the principle, construction, working, advantages (any two) and disadvantages (any two) involved in photovoltaic cell. 6M

(b) What is e-pollution? State any four sources and any four bad effects of e-pollution. 5M  
What are the preliminary actions to be taken to avoid e-pollution?

(c) What is acid rain? Give the reactions taking place in the environment during acid rain. 4M  
Give any two bad effects of acid rain.

\*\*\*\*\*