

FE | All Branches | Sem 2 | 30/11/18 | Choice Based

(3 hours)

Total Marks: 80

Note:

1. Question no.1 is compulsory
2. Answer any three from remaining

1. a. Show that $\operatorname{sech}^{-1}(\sin \theta) = \log \cot \left(\frac{\theta}{2} \right)$ (3)

b. Show that the matrix $A = \frac{1}{2} \begin{pmatrix} \sqrt{2} & -i\sqrt{2} & 0 \\ i\sqrt{2} & -\sqrt{2} & 0 \\ 0 & 0 & 2 \end{pmatrix}$ is unitary (3)

c. Evaluate $\lim_{x \rightarrow 0} \sin x \log x$ (3)

d. Find the nth derivative of $y = e^{ax} \cos^2 x \sin x$ (3)

e. If $x = r \cos \theta$ and $y = r \sin \theta$ prove that $JJ' = 1$ (4)

f. Using coding matrix $A = \begin{bmatrix} 2 & 1 \\ 3 & 1 \end{bmatrix}$ encode the message (4)

THE CROW FLIES AT MIDNIGHT

2. a. Find all values of $(1 + i)^{\frac{1}{3}}$ and show that their continued product is $(1 + i)$ (6)

b. Find the non singular matrices P & Q such that PAQ is in normal (6)

form where $\begin{pmatrix} 1 & 2 & 3 & 4 \\ 2 & 1 & 4 & 3 \\ 3 & 0 & 5 & -10 \end{pmatrix}$

c. Find max. and minimum values of $x^3 + 3xy^2 - 15x^2 - 15y^2 + 72x$ (8)

3. a. If $u = e^{xyz} f\left(\frac{xy}{z}\right)$ prove that $x \frac{\partial u}{\partial x} + z \frac{\partial u}{\partial z} = 2xyz u$ (6)

and $y \frac{\partial u}{\partial y} + z \frac{\partial u}{\partial z} = 2xyz u$ and hence show that

$$x \frac{\partial^2 u}{\partial z \partial x} = y \frac{\partial^2 u}{\partial z \partial y}$$

b. By using Regular falsi method solve $2x - 3\sin x - 5 = 0$ (6)

correct to three decimal places

c. If $y = \sin [\log(x^2 + 2x + 1)]$ then prove that (8)

$$(x + 1)^2 y_{n+2} + (2n + 1)(x + 1)y_{n+1} + (n^2 + 4)y_n = 0$$

4. a. State and prove Eulers Theorem for three variables. (6)

b. By using De Moivres Theorem obtain $\tan 5\theta$ in terms of (6)

$$\tan \theta \text{ and show that } 1 - 10 \tan^2 \left(\frac{\pi}{10}\right) + 5 \tan^4 \left(\frac{\pi}{10}\right) = 0$$

c. Investigate for what values of λ and μ the equations (8)

$$2x + 3y + 5z = 9$$

$$7x + 3y - 2z = 8$$

$$2x + 3y + \lambda z = \mu \text{ have}$$

- (i) No solution
- (ii) Unique solution
- (iii) An infinite number of solution

5. a. Find nth derivative of $\frac{1}{x^2 + a^2}$ (6)

b. If $z = f(x, y)$ where $x = e^u + e^{-v}$, $y = e^{-u} - e^v$ then (6)

$$\text{prove that } \frac{\partial z}{\partial u} - \frac{\partial z}{\partial v} = x \frac{\partial z}{\partial x} - y \frac{\partial z}{\partial y}$$

c. Solve by using Gauss Jacobi Iteration method (8)

$$2x + 12y + z - 4w = 13$$

$$13x + 5y - 3z + w = 18$$

$$2x + y - 3z + 9w = 31$$

$$3x - 4y + 10z + w = 29$$

6. a. If $y = \log \left[\tan \left(\frac{\pi}{4} + \frac{x}{2} \right) \right]$ Prove that

(i) $\tan h \frac{y}{2} = \tan \frac{x}{2}$

(ii) $\cos x = 1$

b. If $u = \sin^{-1} \left[\frac{x^{1/3} + y^{1/3}}{x^{1/2} + y^{1/2}} \right]^{1/2}$ prove that

$$x^2 \frac{\partial^2 u}{\partial^2 x} + 2xy \frac{\partial^2 u}{\partial x \partial y} + y^2 \frac{\partial^2 u}{\partial^2 y} = \frac{\tan u}{144} [\tan^2 u + 13]$$

c.(i) Expand $2x^3 + 7x^2 + x - 6$ in powers of $(x - 2)$ by using Taylors theorem. (4)

(ii) Expand $\sec x$ by Maclaurins theorem considering upto x^4 term (4)

(3 Hours)

(80 Marks)

NB:

1. Question No 1 is **compulsory**. Out of the remaining 5 questions, attempt **any 3**.
2. Numbers in square brackets, at the end of question statement, indicate full marks.
3. Assume suitable data, if not given. Clearly mention the same in your answer.
4. Take the magnitude of gravitational acceleration as 9.81 m/s^2 , unless stated otherwise.
5. Figures drawn are not to the scale.

Q.1. Solve any four.

[5 x 4]

- a) Find the resultant of the parallel force system shown in Figure 1 and locate the same with respect to point C.

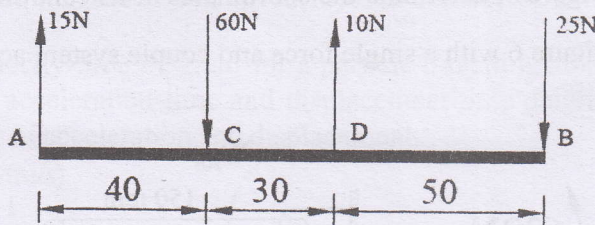

Figure 1

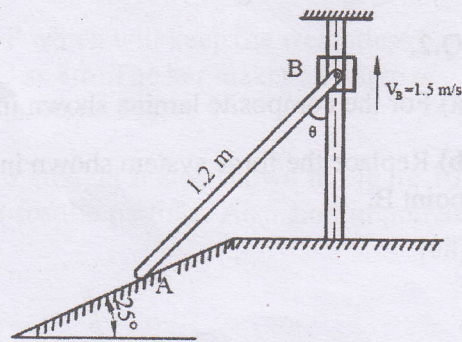

Figure 2

- b) Using Instantaneous Centre of Rotation (ICR) method, find the velocity of point A for the instant shown in Figure 2. Collar B moves along the vertical rod, whereas link AB moves along the plane which is inclined at 25° .

- c) If the support reaction at A, for the beam shown in Figure 3, is zero, then find force 'P' and the support reaction at B.

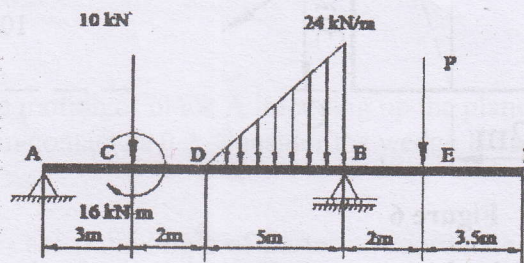

Figure 3

- d) From the top of a tower, 28-m high, a stone is thrown vertically up with a velocity of 9 m/s . After how much time will the stone reach the ground? With what velocity does it strike the ground?

- e) For the truss shown in Figure 4, find: (i) zero force members, if any (Justify your answer with FBD), (ii) support reactions at C and D.

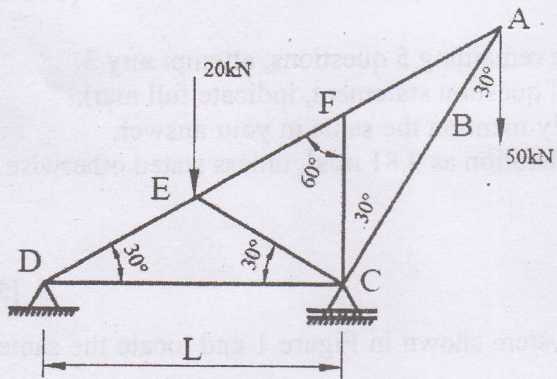

Figure 4

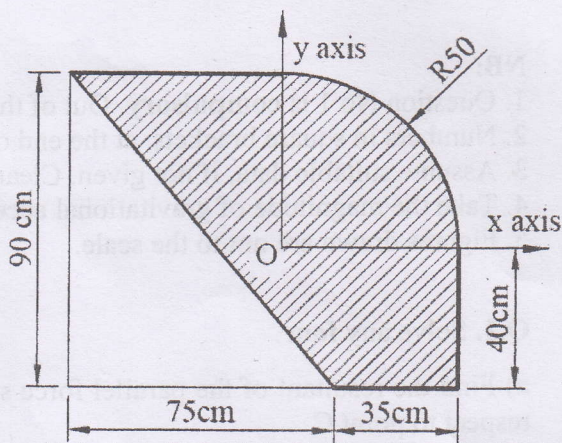

Figure 5

Q.2.

- For the composite lamina shown in Figure 5, determine the coordinates of its centroid. [08]
- Replace the force system shown in Figure 6 with a single force and couple system acting at point B. [05]

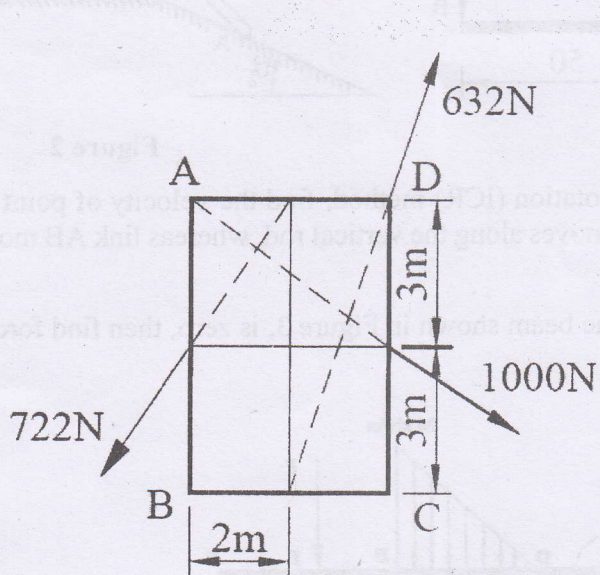

Figure 6

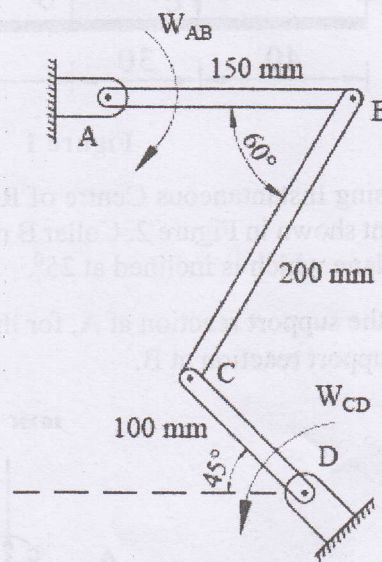

Figure 7

- The link CD of the mechanism shown in Figure 7 is rotating in counterclockwise direction at an angular velocity of 5 rad/s. For the given instance, determine the angular velocity of link AB [07]

Q.3.

- Cylinder A (diameter 1m, weight 20kN) and cylinder B (diameter 1.5m, weight 40kN) are arranged as shown in Figure 8. Find the reactions at all the contact points. All contacts are smooth. [06]

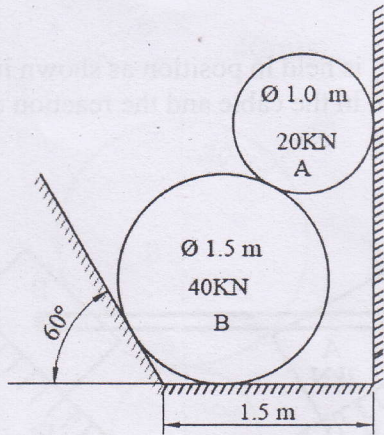

Figure 8

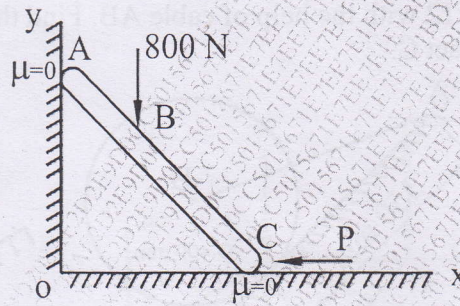

Figure 9

b) Using Principle of Virtual Work, determine the force P which will keep the weightless bar AB in equilibrium. Take length AB as 2m and length AC as 8m. The bar makes an angle of 30° with horizontal. All the surfaces in contact are smooth. Refer Figure 9. [06]

c) Velocity-time diagram for a particle travelling along a straight line is shown in Figure 10. Draw acceleration-time and displacement-time diagram for the particle. Also find important values of acceleration and displacement. [08]

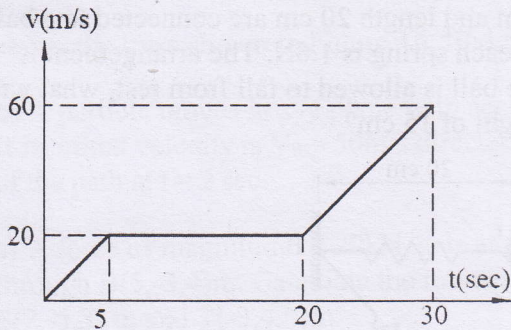

Figure 10

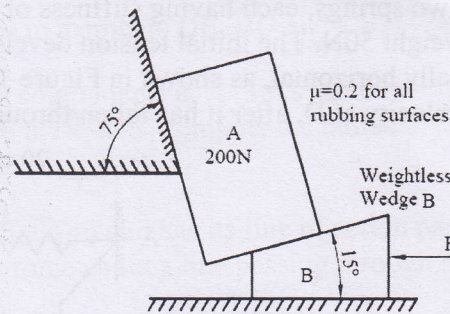

Figure 11

Q.4.

a) Find the force 'F' to have motion of block A impending up the plane. Take coefficient of friction for all the surfaces in contact as 0.2. Consider the wedge B as weightless. Refer Figure 11. [07]

b) Three forces F_1 , F_2 and F_3 act at the origin of Cartesian coordinate axes system. The force F_1 ($= 70\text{N}$) acts along OA whereas F_2 ($= 80\text{N}$) acts along OB and F_3 ($= 100\text{N}$) acts along OC. The coordinates of the points A, B and C are (2,1,3), (-1,2,0) and (4,-1,5) respectively. Find the resultant of this force system. [05]

c) A 75kg person stands on a weighing scale in an elevator. 3 seconds after the motion starts from rest, the tension in the hoisting cable was found to be 8300N. Find the reading of the scale, in kg during this interval. Also find the velocity of the elevator at the end of this interval. The total mass of the elevator, including mass of the person and the weighing scale, is 750kg. If the elevator is now moving in the opposite direction, with same magnitude of acceleration, what will be the new reading of the scale? [08]

Q.5.

a) The cylinder B, diameter 400mm and weight 5kN, is held in position as shown in Figure 12 with the help of cable AB. Find the tension in the cable and the reaction developed at contact C. [04]

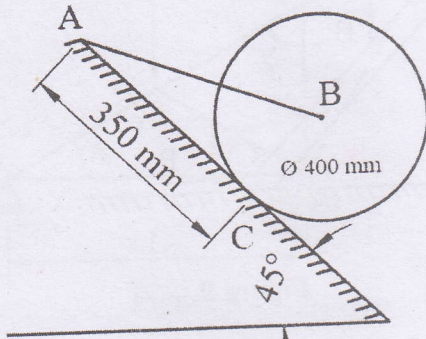

Figure 12

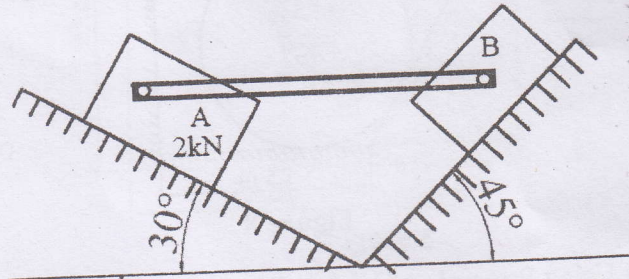

Figure 13

b) Find the weight W_B so as to have its impending motion down the plane. Take weight of block A as 2kN. The pin connected rod AB is initially in horizontal position. Refer Figure 13. [05]

c) Two springs, each having stiffness of 0.6N/cm and length 20 cm are connected to a ball B of weight 50N. The initial tension developed in each spring is 1.6N. The arrangement is initially horizontal, as shown in Figure 14. If the ball is allowed to fall from rest, what will be its velocity at D, after it has fallen through a height of 15 cm? [05]

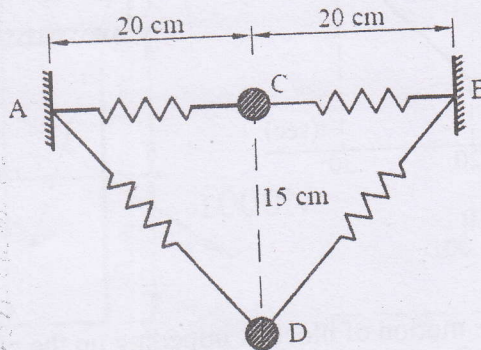

Figure 14

d) Two balls, A (mass 3kg) and B (mass 4kg), are moving with velocities 25 m/s and 40 m/s respectively (Refer Figure 15). Before impact, the direction of velocity of two balls are 30° and 50° with the line joining their centers as shown in Figure 15. If coefficient of restitution for the impact is 0.78, find the magnitude and the direction of velocities of the balls after the impact. [06]

FE, sem.-I, Choice Base, SH2018

13/12/18

(Three Hours)

(Marks :80)

- N.B:** (1) Question No.1 is compulsory.
 (2) Answer any THREE from the remaining five questions.
 (3) Assume suitable data if required and state the assumption.

Q1. Answer any five.

(i) Find the RMS value of the waveform given below. (4)

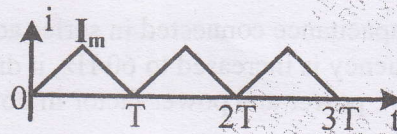

(ii) State Norton's theorem and draw the Norton's equivalent circuit. (4)

(iii) In an R-L-C parallel circuit the current through the resistor, inductor (pure) and capacitor (pure) are 20 A, 15 A and 40 A respectively. What is the current taken from the supply? Draw the phasor diagram. (4)

(iv) A balanced 3- Φ , star-connected load consists of three coils each consisting of $R=6\Omega$ and $X_L=8\Omega$. Determine the line current, power factor when the load is connected across 400 V, 50 Hz supply. (4)

(v) Briefly explain the classification of dc machine. (4)

(vi) Draw the phasor diagram of a single phase transformer when it is loaded with a lagging power factor load. (4)

Q2. (A) Prove that the average power taken by a pure capacitor fed with a sinusoidal ac supply in a cycle is zero. (10)

(B) Using mesh analysis find the mesh currents in the direction shown and also find the voltage across A and B terminals. (10)

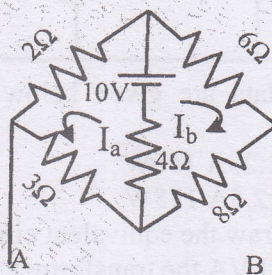

Q3. (A) A single phase transformer has 1000 turns on the primary and 200 turns on the secondary. The no load current is 3A at a power factor of 0.2 lag and the secondary current is 280A at a power factor of 0.8 lag. Neglect R_2 and X_2 . Calculate (i) Magnetizing component and loss component of no load current; (ii) Primary current (iii) Input power factor. Draw the phasor diagram showing all these currents. (10)

(B) Derive the formula for resonant frequency of the circuit with a pure capacitor in parallel with a coil having resistance and inductance. Find the expression for dynamic resistance of this parallel resonant circuit. (10)

- Q4. (A) Find current I_x using Superposition theorem. (10)

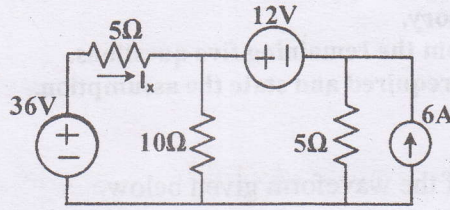

- (B) A resistance and a capacitance connected in series across a 250V supply draws 5A at 50 Hz. When frequency is increased to 60 Hz, it draws 5.8A. Find the values of R & C. Also find active power and power factor in both cases. (10)

- Q5. (A) Find the node voltages V_1 , V_2 and V_3 and current through 0.5Ω . (10)

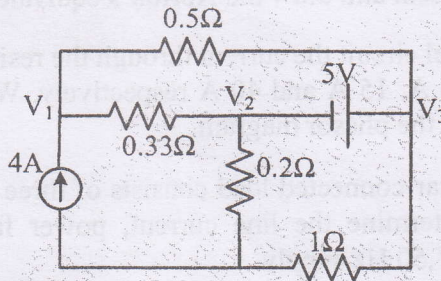

- (B) Describe the basic principle of operation of a single phase transformer and derive the emf equation. (10)

- Q6. (A) Determine the value of R for maximum power transfer and find the value of maximum transfer. (10)

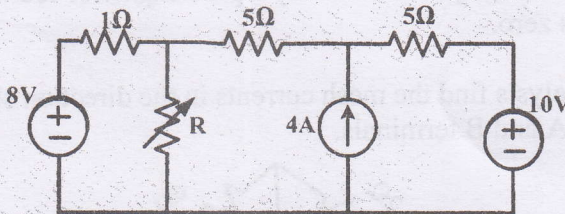

- (B) The O.C and S.C test data are given below for a single phase, 5 kVA, 200V/400V, 50Hz transformer. (10)

O.C test from LV side: 200V 1.25A 150W

S.C test from HV side: 20V 12.5A 175W

Determine the following: (i) Draw the equivalent circuit of the transformer referred to LV side (ii) At what load or kVA the transformer is to be operated for maximum efficiency? (iii) Calculate the value of maximum efficiency. (iv) Regulation of the transformer at full load 0.8 power factor lag.

FE (Sem-2) Choice Based / All Branches / 19/12/18

Time: 2 Hours

Marks: 60

N. B.

1. Question number 1 is compulsory.
2. Attempt any three questions from Q.2 to Q.6.
3. Draw neat diagrams and write chemical equations where necessary.
4. Figures to right indicate full marks.

Atomic Weight: H=1, C=12, O=16, Ca=40, Na=23, Mg=24, S=32, Cl=35.5, N=14, Al=27, K=39

1. Solve any five.
 - (a) Explain the principle of EDTA method. 3
 - (b) What is glass transition temperature. Write its significance. 3
 - (c) Write the significance of the following properties of lubricants:
i) Emulsification ii) Cloud point iii) Fire point 3
 - (d) What is RCC? What are the advantages of RCC over concrete? 3
 - (e) Explain the reduced phase rule. 3
 - (f) Distinguish between thermoplastic and thermosetting polymer. 3
 - (g) 20 ml sample of waste water was refluxed with 30 ml of potassium dichromate solution and after refluxing the excess unreacted dichromate required 11 ml of 0.1 N FAS solution. Blank of 20 ml of distilled water on refluxing with 30 ml of dichromate solution required 14 ml of 0.1 N FAS solution. Calculate the COD value of wastewater. 3
2. (a) A sample of water contains following impurities: 6

$\text{Mg}(\text{HCO}_3)_2=73\text{mg/lit}$, $\text{MgSO}_4=120\text{ mg/lit}$, $\text{CaCl}_2=222\text{ mg/l}$ and $\text{Ca}(\text{NO}_3)_2=164\text{ mg/lit}$. The purity of lime is 74% and soda is 90%. Calculate the quantity of lime and soda needed for softening of 50,000 litres of water.

 - (b) i) Write a brief note on polymers used in medical field. 3
 - ii) Name two additives added in blended oils. Give one example of each. 2
 - (c) Explain with the help of chemical reactions "Setting and Hardening" of cement. 4
3. (a) What is fabrication of plastic? Explain injection moulding process with a neat diagram. 6
 - (b) i) Discuss the advantages and limitations of phase rule. 3
 - ii) Differentiate between SWNT and MWNT 2

- (c) A zeolite softener was completely exhausted and was regenerated by passing 1000 litres of NaCl solution, containing 100mg/lit of NaCl. How many litres of a sample water of hardness 500ppm can be softened by this softener? 4
4. (a) Draw the diagram for demineralization process and write suitable reactions involved in the process. What are the advantages and disadvantages of the method. 6
- (b) i) Find the acid value of the given oil whose 20ml required 2.8ml of N/10 KOH during titration. (Density of oil = 0.86g/ml) 3
 ii) Write a short note on decay of concrete. 2
- (c) Natural rubber requires vulcanization. Give reasons. With appropriate reactions explain how the drawbacks are overcome? 4
5. (a) Write preparation, properties and uses of following polymers: (Any two) 6
 i) Kevlar ii) Silicone rubber iii) Buna S
- (b) i) Explain Activated sludge method with the help of diagram. 3
 ii) What is grease? What are the conditions in which greases are used? 2
- (c) Draw the phase diagram of one component system and find out the number of degree of freedom along the curves and areas. 4
6. (a) What are lubricants? Define Lubrication. Explain Hydrodynamic lubrication mechanism with neat diagram. 6
- (b) i) Define a) Phase b) Component c) Degree of freedom 3
 ii) Write a short note on Reverse Osmosis. 2
- (c) Explain laser ablation method for production of CNTs. 4

FE (Sem-II) (Choice Band) All Branches | 24/12/18

[Max. Marks= 60]

(2 Hours)

- N.B: 1) Question number 1 is Compulsory.**
 2) Attempt any three questions from Q.2 to Q.6.
 3) Assume suitable data wherever required.
 4) Figures to the right indicate full marks.

Q.1. Attempt any Five questions from the following.

(15)

- (a) Draw (123), (321), ($\bar{1}02$). (1)
- (b) Explain with diagram HCP unit cell based on lattice parameters. (1)
- (c) State properties of matter waves. (1)
- (d) Calculate electron & hole concentration in intrinsic Si at room temperature if its electrical conductivity is 4×10^{-4} mho/m. Given that mobility of electron = $0.14 \text{ m}^2/\text{V-sec}$ and mobility of holes = $0.04 \text{ m}^2/\text{V-sec}$. (3)
- (e) Explain Meissner Effect with the help of diagram. (1)
- (f) A conference room has a total volume of 2000 m^3 . The magnitude of total absorption within the conference room is 100 sabin. Calculate the reverberation time. (1)
- (g) Discuss any three applications of Ultrasonic waves. (4)

Q.2.

- (a) State Heisenberg's Uncertainty Principle. Show that electron doesn't exist in the nucleus. Find the accuracy in the position of an electron moving with speed 350 m/sec with uncertainty of 0.01%. (8)
- (b) Show that for intrinsic semiconductors the Fermi level lies midway between the conduction band and the valence band. With the help of diagram explain effect of impurity concentration on Fermi level of N type semiconductor. (7)

Q.3.

- (a) Derive Bragg's condition for X-ray diffraction. Monochromatic X rays are incident on a crystal. If first order reflection is observed at an angle 3.4° , at what angle would second order reflection be expected. (8)
- (b) Derive an expression for Hall voltage and Hall coefficient with neat labelled diagram. (7)

Q.4.

- (a) Differentiate between Type-I & Type-II Superconductors. (5)
- (b) Discuss in details any three factors affecting acoustics of a hall with their remedies. (5)
- (c) A quartz crystal of thickness 1mm is vibrating at resonance. Calculate its fundamental frequency. (Assume that for quartz, $Y = 7.9 \times 10^{10} \text{ N/m}^2$ and $\rho = 2.650 \text{ gm/cc}$.) (5)

Q.5.

- (a) Define Ligancy. Find the value of critical radius ration for Ligancy 3. (5)
- (b) For an electron passing through potential difference 'V', show that its wavelength is; (5)

$$\lambda = \frac{12.26}{\sqrt{V}} \text{ \AA}$$

- (c) What is the probability of an electron being thermally excited to conduction band in Si at 27°C . The band gap energy is 1.12 eV. (5)

Q.6.

- (a) Explain Point defects in crystals. (5)
- (b) Show that group velocity of matter waves associated with a particle is equal to the particle velocity ($V_{\text{group}} = V_{\text{particle}}$). (5)
- (c) Explain the principle, construction and working of Light Emitting Diode. (5)

FE, sem-I, Choice Base, SH2018

27/12/18

[Time: 2 Hours]

[Marks:60]

Please check whether you have got the right question paper.

- N.B:
1. Question.No.1 is compulsory.
 2. Attempt any **three** questions from Q. 2 to Q. 6.
 3. Draw neat labelled **diagrams** wherever applicable.
 4. Figures to right indicate **full marks**.

Q.1 Answer any five from the following:-

15

- a) What are reasons for the depletion of soil resources?
- b) Explain principle involved in working of photovoltaic cells.
- c) Write a brief note on Noise Pollution.
- d) Define 'Sustainable Development'. Why there is need for sustainable development?
- e) Explain the term - 'carbon credits'.
- f) What are the sources and consequences of Greenhouse effect?
- g) Why there is need for public awareness on environmental education.

Q.2

- a) Write important features of case study on Narmada Bachao Andolan, took place in Gujarat in 1980. 5
- b) Draw flow sheet diagram and explain the process of industrial waste water treatment. 5
- c) Draw a schematic of flat plate collector and explain its role in trapping solar energy. 5

Q.3

- a) Give brief account of case study on London smog occurred in U.K. in December, 1952. 5
- b) Write a brief note on environmental clearance and authorization mechanism. 5
- c) Write the effects produced by different Indoor Air Pollutants. 5

Q.4

- a) What is ecological succession? What is its impact? 5
- b) Write important powers and functions of State Pollution Control Board (SPCB). 5
- c) Draw a neat labelled diagram and explain the process of generating electricity from geothermal energy. 5

Q.5

- a) Explain Economic and Environmental aspects associated with sustainable development. 5
- b) Draw a neat diagram and explain working of Venturi Scrubber. 5
- c) Draw a neat schematic and explain the process of hydropower generation. 5

Q.6

- a) Explain the reasons and effects of depletion of our natural forest resources. 5
- b) How solid waste management is carried out by composting? 5
- c) Explain the objectives of 'Green Building'. 5