

SE/III choice Board/ETC/20/11/18

(3 Hours)

[Total Marks: 80]

N.B.: 1) Question No. 1 is Compulsory.

2) Answer any THREE questions from Q.2 to Q.6.

3) Figures to the right indicate full marks.

Q.1 (a) Evaluate $\int_0^{\infty} e^{-2t} t \sin t \, dt$. (5)

(b) Find a, b, c, d, e if $f(z) = (ax^3 + bxy^2 + 3x^2 + cy^2) + i(dx^2y - 2y^3 + exy)$ is analytic. (5)

(c) Find half range sine series of $f(x) = x(\pi - x)$, $0 < x < \pi$. (5)

(d) Find directional derivative of $\phi = 4xz^2 + x^2yz$, at $(1, -2, -1)$ in direction of $2i - j - 2k$. (5)

Q.2 (a) Prove that $\nabla r^n = nr^{(n-2)} \hat{r}$. (6)

(b) Find Bilinear Transformation which maps the points $z = -1, 0, 1$ onto the points $w = -1, -i, 1$. (6)

(c) Find i) $L^{-1} \left[\frac{e^{-2s}}{s^2 + 3s + 2} \right]$ ii) $L^{-1} \left[\log \left(\frac{s^2 + 4}{s + 4} \right) \right]$. (8)

Q.3 (a) Use Gauss's Divergence Theorem to evaluate $\iiint_S \bar{N} \cdot \bar{F} \, ds$ where (6)

$\bar{F} = 4xi - 2y^2j + z^2k$ and s is region bounded by $x^2 + y^2 = 4, z = 0, z = 4$.

(b) Find Laplace Transform of $e^{-2t} \int_0^t u e^{3u} \cos 4u \, du$. (6)

(c) Obtain Fourier series of $f(x) = \begin{cases} x + \frac{\pi}{2} & -\pi < x < 0 \\ \frac{\pi}{2} - x & 0 < x < \pi \end{cases}$ (8)

Hence deduce $\frac{\pi^4}{96} = \frac{1}{1^4} + \frac{1}{3^4} + \frac{1}{5^4} + \dots$

Q.4 (a) Show that set of functions $\left\{ \frac{\sin x}{\sqrt{\pi}}, \frac{\sin 2x}{\sqrt{\pi}}, \frac{\sin 3x}{\sqrt{\pi}} \dots \right\}$ form an orthonormal set in $(-\pi, \pi)$. (6)

(b) Find orthogonal trajectories of the family of curves $e^x \cos y - xy = c$. (6)

(c) Prove that $\vec{F} = (6xy^2 - 2z^3)\mathbf{i} + (6x^2y + 2yz)\mathbf{j} + (y^3 - 6z^2x)\mathbf{k}$ is irrotational. Find scalar potential of \vec{F} . Hence find the work done of moving particle from (1,0,2) to (0,1,1). (8)

Q.5 (a) Find Fourier Integral representation for $f(x) = \begin{cases} 1-x^2 & |x| \leq 1 \\ 0 & |x| > 1 \end{cases}$ (6)

(b) Solve using Laplace Transform $\frac{d^2y}{dt^2} + 2\frac{dy}{dt} + y = te^{-t}$ given $y(0) = 4$ and $y'(0) = 2$. (6)

(c) Verify Green's Theorem for $\vec{F} = x^2\mathbf{i} - xy\mathbf{j}$ and c is triangle having vertices $A(0,2), B(2,0), C(4,2)$. (8)

Q.6 (a) Using Convolution theorem, find Inverse Laplace of $\frac{s}{(s^2+4)^2}$. (6)

(b) Prove that $J_{\frac{1}{2}}(x) = \sqrt{\frac{2}{\pi x}} \left[\frac{3}{x} \sin x + \frac{(3-x^2)}{x^2} \cos x \right]$. (6)

(c) Find Fourier series for $f(x) = (\pi - x)^2$ in $0 \leq x \leq 2\pi$. Hence deduce (8)

that $\frac{\pi^2}{8} = \frac{1}{1^2} + \frac{1}{3^2} + \frac{1}{5^2} + \dots$

SE | II | choice based | ETEC | 28/11/18

QP : Code : 25071

(3 Hours)

[Total Marks : 80

Note: 1) Question no. 1 is compulsory.

2) Solve any three questions out of remaining.

3) Fig. to the right indicates maximum marks.

4) Assume suitable data wherever necessary but justify the same.

Q1. Solve any five.

(5x4 = 20)

a) Determine the value of R_c such that $V_c = 5V$ and $\beta = 50$.

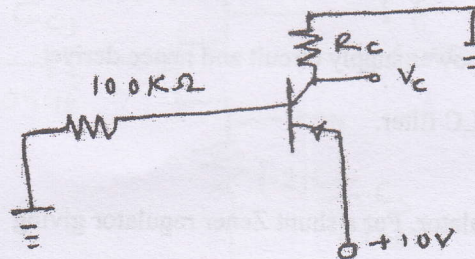

b) State and explain Miller's Theorem.

c) Design a self bias circuit using JFET for $I_D = 3mA$, $V_{DD} = 20V$ and $V_{DS} = 0.6 V_{DD}$.

($I_{DSS} = 8mA$, $V_p = -4V$)

d) Explain various types of capacitors.

e) Determine the values of coupling capacitors C_{C1} and C_{C2} if $r_{\pi} = 1.5K\Omega$, $\beta = 120$ and $f_L = 20Hz$.

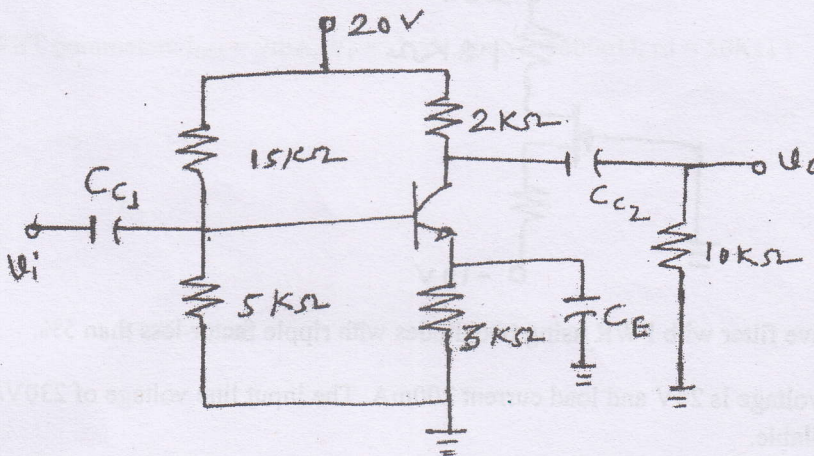

f) Explain concept of zero temperature drift in JFET.

[TURN OVER

Q2. A) Calculate 1) I_{BQ} , I_{CQ} 2) g_m , r_{π} 3) Small signal voltage gain 10

For the circuit given below.

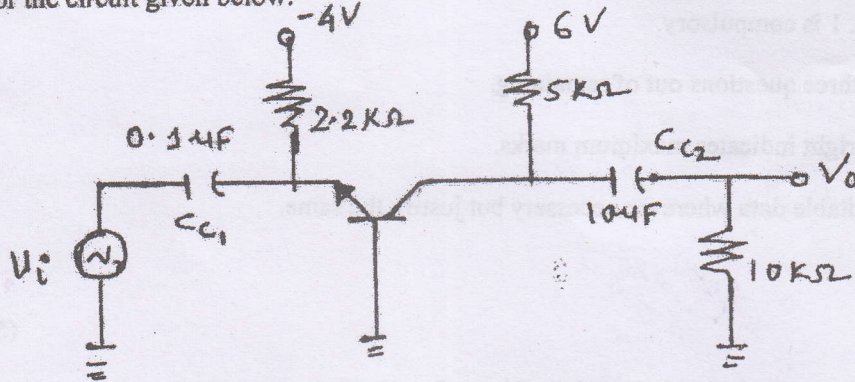

Q2 B) Explain the concept of LC filter in power supply circuit and hence derive expression for ripple factor of LC filter. 10

Q3 A) Explain concept of shunt Zener regulator. For a shunt Zener regulator giving 10

output voltage of 10 V and load resistance varying from $5K\Omega$ to $10K\Omega$, V_{in} is varying between 18V to 22V.

Find R_s , P_{zmax} , S_v and R_o .

Assume $R_z = 4\Omega$ and $I_{zmin} = 50\mu A$.

B) Determine I_{DQ} , V_{GSQ} , V_{DSQ} if $I_{DSS} = 9mA$ and $V_p = -3V$ for the circuit given below. 10

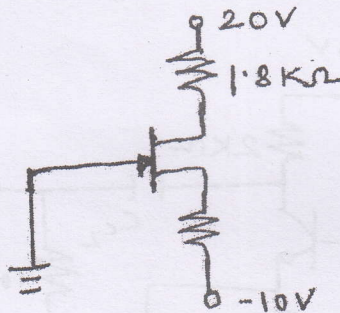

Q4 A) Design capacitive filter with FWR using two diodes with ripple factor less than 5%. 10

Output voltage is 24V and load current 200mA. The input line voltage of 230V/ 50Hz is available.

B) Determine the values of biasing components for a CE configuration if $V_{cc} = 12V$, 10

$V_{CE} = 6V$, $R_c = 1K\Omega$, $V_{BE} = 0.6V$, $\beta = 180$ for the following circuit.

- i) Fixed bias without R_E
- ii) Voltage Divider bias with $V_{RE} = 10\%$ of V_{cc} and $S_1 = 8$

[TURN OVER

Q5 A) For JFET if $I_{DSS} = 6 \text{ mA}$, $V_P = -6\text{V}$, $r_d = \infty$, $C_{gd} = 4\text{pF}$, $C_{gs} = 6\text{pF}$, $C_{ds} = 1\text{pF}$ 15

Determine i) V_{GSQ} ii) I_{DQ}

- iii) g_{mo} iv) g_m
- v) Midband voltage gain A_v
- vi) Higher cut off frequency

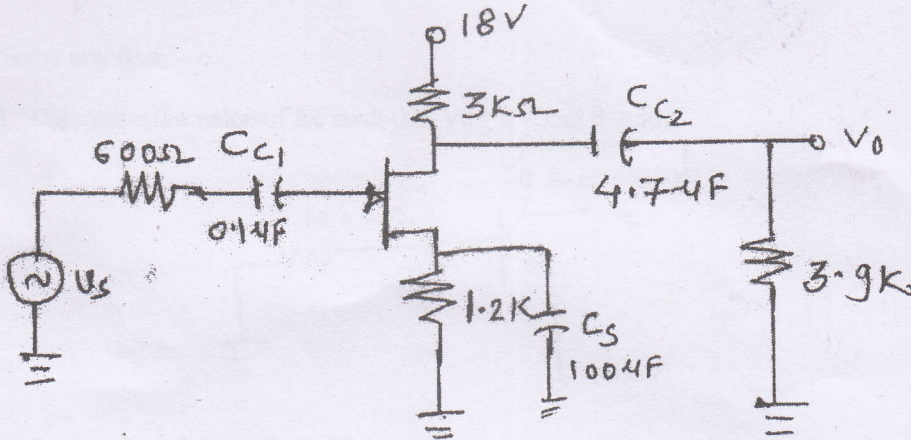

B) Explain high frequency \square equivalent model of common emitter BJT.

5

Q6. Design single stage CS amplifier using mid-point biasing method for voltage gain of 12, 20

$F_L = 20 \text{ Hz}$, $R_L = 10\text{k}\Omega$, $V_o = 3.5\text{V}$

(Use JFET parameters $I_{DSS} = 7\text{mA}$, $V_P = -2.5\text{V}$, $g_{mo} = 5600\mu\text{S}$, $r_d = 50\text{k}\Omega$)

SE, sem-III, Elect. & Telecom., 5/12/08
 (choice base) (3 Hours) Max Marks: 80

1. Question No. 1 is compulsory.
2. Out of remaining questions, attempt any three questions.
3. Assume suitable additional data if required.
4. Figures in brackets on the right hand side indicate full marks.

- Q.1 (A) Explain Static RAM. (05)
 (B) Compare Moore and Mealy machines. (05)
 (C) Which of the following expression is equivalent to $Z = \overline{\overline{A(AB)} \cdot \overline{\overline{B(AB)}}}$? (01)
 i) $Z = A \oplus B$ ii) $Z = \overline{A \oplus B}$
 iii) $Z = A + B$ iv) $Z = \overline{A \cdot B}$
 Prove it. (04)
 (D) Perform the following operation using 2's complement (02)
 i) $(46)_{10} - (23)_{10}$ (02)
 ii) $(23)_{10} - (46)_{10}$ (02)
 Comment on results of (i) and (ii). (01)
- Q.2 (A) Compare Combinational circuits with Sequential circuits. (05)
 (B) Convert the following into BCD and Octal code (05)
 i) $(AB)_{16}$ ii) $(118)_{10}$
 (C) Draw and explain a neat circuit diagram of BCD adder using IC 7483. (10)
- Q.3 (A) Minimize the following expression using Quine McClusky Technique (10)
 $F(A, B, C, D) = \sum m(1, 3, 7, 11, 15) + d(0, 2, 5)$
 (B) Implement the following function using single 8:1 Multiplexer. (10)
 $f(A, B, C, D) = \sum m(2, 3, 5, 7, 8, 9, 12, 13, 14, 15)$
- Q.4 (A) What is excitation table? Explain the excitation table of SR flip flop. (05)
 (B) Convert SR flip flop to JK flip flop. (05)
 (C) What is shift register? Explain working of Serial In Serial Out. Give its applications. (10)
- Q.5 (A) Simplify the following expression using Boolean algebra: (05)
 $Y(A, B, C) = \sum m(0, 1, 2, 3, 4, 5, 6, 7)$
 (B) Represent the following Boolean expression by min/max terms (05)
 $Y(A, B, C, D) = (A + B + \overline{C})(\overline{A} + C + \overline{D})$
 (C) Design synchronous counter using D-type flip-flops for getting the following sequence: 0 - 2 - 4 - 6 - 0. Take care of lockout condition. (10)
- Q.6 (A) Write VHDL code for 3:8 Decoder. (05)
 (B) Compare FPGA and CPLD. (05)
 (C) Design Full Adder circuit using PLA. (10)

SE, sem-III, Choice Base, Elect. & Telecom, 5H2018

[Time: 3 Hours]

[Marks:80]

Please check whether you have got the right question paper.

11/12/18

- N.B:
1. Question one is compulsory.
 2. Answer any three questions from the remaining five.
 3. Assume suitable data if required.

1. Answer all the questions
 - a) Find R_1 and R_2 in the following circuit.

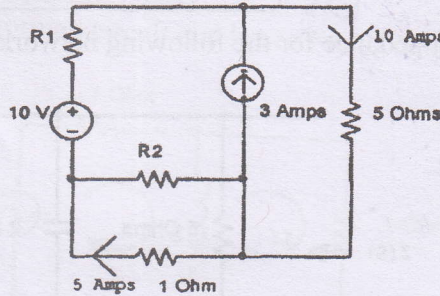

05

- b) Find h parameters for the following 2-port network.

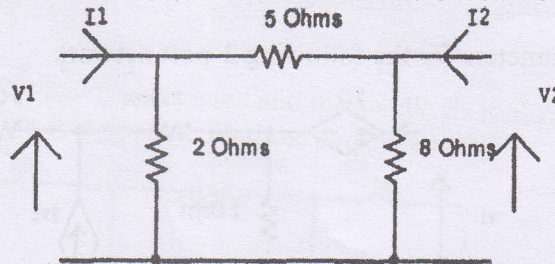

05

- c) The poles of a driving point impedance function are at 0, -5, and zero at -2, find the function if $Z(-3) = 1/6$ and synthesize the same in cauer-I form.

05

- d) Draw the graph of the following network and obtain incidence matrix.

05

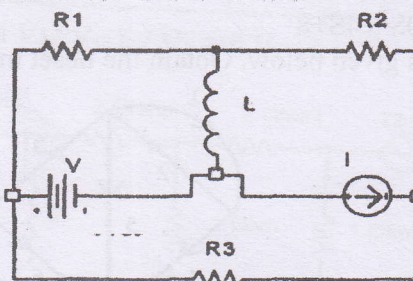

2. a) For the circuit shown below, find the current through 3 ohms resistor, using superposition theorem.

10

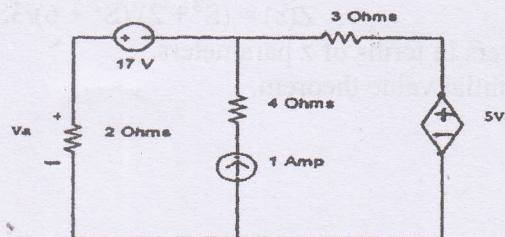

- b) In the following series RC circuit the switch is closed at $t=0$, find the expression for the current through the capacitor and sketch $i(t)$ versus t . 05

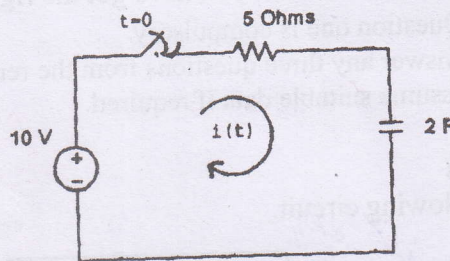

- c) Find the driving point impedance for the following network. 05

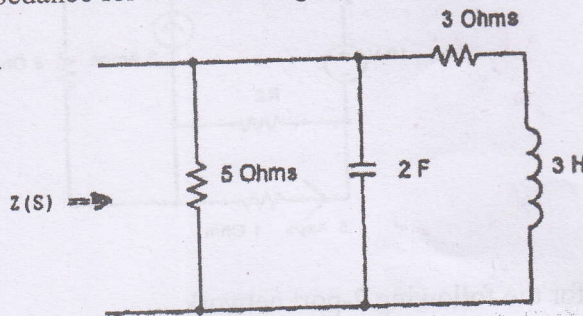

3. a) Find the ABCD parameters for the following 2-port network 10

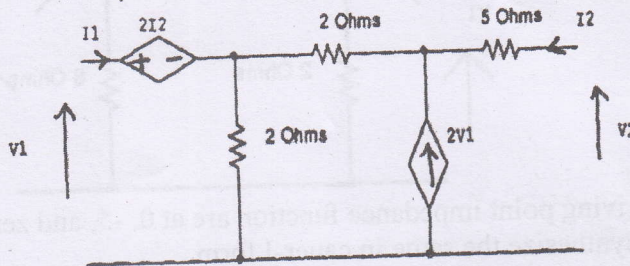

- b) Check whether the following functions are Hurwitz 05
 i) $F(S) = S^5 + 4S^3 + 2S$
 ii) $F(S) = S^5 + 2S^4 + 5S^3 + 10S^2 + 4S + 8$
 c) The graph of a network is given below. Obtain the tieset matrix.

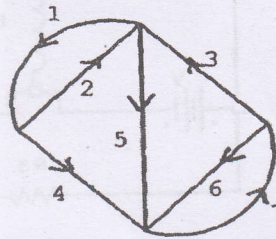

4. a) Synthesize the following driving point impedance function in Cauer-I and Foster-I forms. 10
 $Z(s) = (S^2 + 2)(S^2 + 6)/3S(S^2 + 5)$
 b) Obtain h parameters in terms of z parameters. 05
 c) State and prove initial value theorem. 05

EXTC - CHOICE BASE

5. a) For the following network obtain the KVL equilibrium equation in matrix form using the concept of graph theory and hence find the link currents. 10

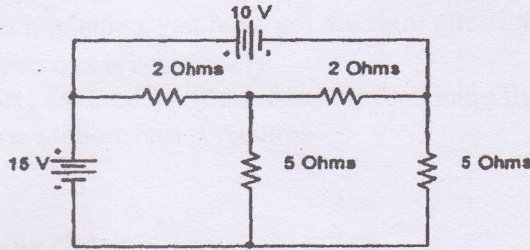

- b) Find $I_2(S)$ for the following transformed circuit and hence find $i_2(t)$ using Inverse Laplace Transform. 05

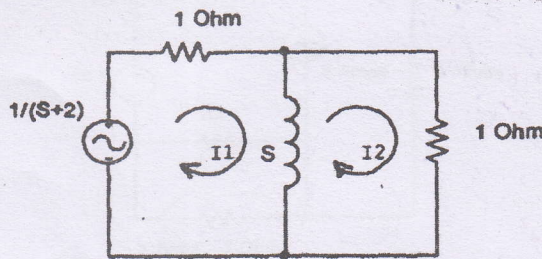

- c) Test whether the following function is a Positive Real function. 05
 $F(s) = (S^4 + 14S^2 + 45) / (S^3 + 7S)$

6. a) In the circuit given below, the switch S_1 is opened and the switch S_2 is closed at $t=0$. The switch S_1 was closed for a long time before it is opened. Find the current $i_2(t)$ 10

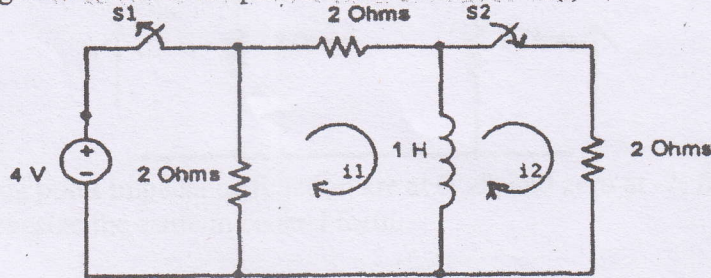

- b) For the following ladder network find V_2 / V_1 , I_1 / V_1 and V_2 / I_1 10

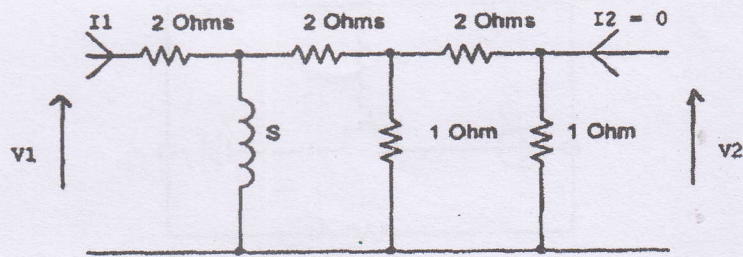

8E(14) choice Based | ETC | 17/12/18 Q.P. Code: 22929

(3Hours)

Total Marks:

80

- Instructions** – i) Questions 1 is Compulsory
 ii) Out of remaining questions attempt any three questions
 iii) Assume suitable additional data if required.
 iv) Figures in the bracket to the right hand side indicate full marks.

Q.1 Solve any five

- a) Describe how Q Meter is used for measurement of low impedance. (04)
- b) Explain various criteria for selection of transducers. (04)
- c) Give basic block diagram of telemetry system and explain each component. (04)
- d) Find transfer function for following system (04)

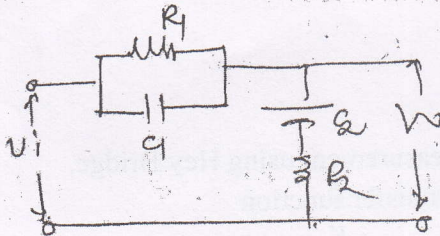

- e) Explain concept of stability, absolute stability and conditional stability. (04)
- f) Draw polar plot of (04)

$$G(s)H(s) = \frac{14}{s(s+1)(s+2)}$$

Q.2 a) 1) Find C(s)/R(s) using Mason's gain formula (10)

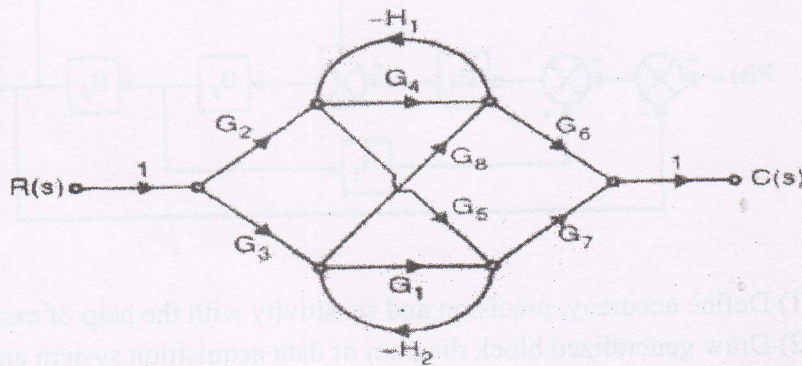

2) A unity feedback system has (05)

$G(s) = \frac{K}{s(s+2)(1+0.5s)}$. Find steady state error if $r(t)=3t$ and $K=4$. Also calculate K for $e_{ss}=0.4$.

Q.2 b) What are the various sources of errors in Q meter? (05)

Q.3 a) A unity feedback system has (10)

$$G(S) = \frac{K}{S(S + 1)(S + 2)(S + 4)}$$

Find the following using Routh –Hurwitz’s criterion

- 1) the range of K for stability
- 2) The value of K for marginal stability

Q.3 b) Explain with neat diagram principle of operation of LVDT. An LVDT produces output of 5V; when the core displacement is 20mm from zero position. Calculate core displacement when the output is 2.5V. (10)

Q.4 a) Draw the Bode Plot for a system having $G(s)H(s) = 100/s(s+1)(s+2)$ (15)

Find-

- (a) Gain Margin
- (b) Phase Margin
- (c) Gain Crossover freq.
- (d) Phase crossover freq.

Q.4 b) Derive expression for inductance measurement using Hey Bridge. (05)

Q.5 a) Sketch root locus for the following transfer function (10)

$$G(S)H(s) = \frac{K}{S(S + 4)(S + 6)}$$

Q.5 b) Explain Kelvin’s double bridge and its application in low resistance measurement and derive expression for unknown resistance. (10)

Q.6 a) Find C(s)/R(s) for the given system (10)

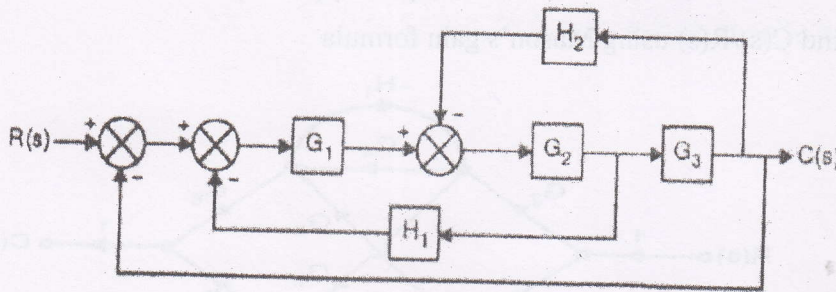

Q.6 b) 1) Define accuracy, precision and sensitivity with the help of examples. (05)

2) Draw generalized block diagram of data acquisition system and explain the blocks. (05)
