

SE | EXTC | IV | Choice Band | 19/11/18

(3 hours)

Total Marks:80

N.B: (1) Question no.1 is compulsory.

(2) Attempt any three questions from remaining five questions.

(3) Figures to the right indicate full marks.

(4) Assume suitable data if necessary.

1. (a) if $A = \begin{pmatrix} 2 & 4 \\ 0 & 3 \end{pmatrix}$, then find the eigen values of $6A^{-1} + A^3 + 2I$. (5)

(b) Find a vector orthogonal to both $u = (-6, 4, 2), v = (3, 1, 5)$. (5)

(c) Show that $\oint_C \log z dz = 2\pi i$, Where C is the unit circle in the Z-plane. (5)

(d) Let X be continuous random variable with probability distribution

$$p(X = x) = \begin{cases} \frac{x}{6} + k, & \text{if } 0 \leq x \leq 3 \\ 0, & \text{elsewhere} \end{cases}$$

Evaluate k and find $p(1 \leq x \leq 2)$. (5)

2. (a) Show that the matrix A is diagonalizable. Also find the transforming matrix M and the

diagonal matrix D where $A = \begin{bmatrix} -9 & 4 & 4 \\ -8 & 3 & 4 \\ -16 & 8 & 7 \end{bmatrix}$. (6)

(b) Find the extremals of the function $\int_0^{\frac{\pi}{2}} ((y')^2 - y^2 + 2xy) dx$ with $y(0) = 0, y(\frac{\pi}{2}) = 0$. (6)

(c) Let R^3 have the Euclidean inner product. Use Gram-Schmidt process to transform the

basis $\{u_1, u_2, u_3\}$ in to an orthonormal basis where $u_1 = (1, 0, 1, 1), u_2 = (-1, 0, -1, 1), u_3 = (0, -1, 1, 1)$. (8)

3. (a) The number of accidents in a year attributed to taxi driver in a city follows poisson distribution with mean 3. Out of 1,000 taxi drivers, find approximately the number of drivers with (i) No accident in a year (ii) more than 3 accident in a year.

(Given $e^{-1} = 0.3679, e^{-2} = 0.1353, e^{-3} = 0.0498$) (6)

(b) Calculate Rank Correlation co-efficient for the following data:

X:	10	12	18	18	15	40
Y:	12	18	25	25	50	25

(6)

(c) Expand $f(z) = \frac{1}{z^2(z-1)(z+2)}$ about $z=0$ for

- (i) $|z| \leq 1$ (ii) $1 \leq |z| \leq 2$ (iii) $|z| > 2$. (8)

4.(a) Evaluate $\oint_C \frac{\sin^6 z}{\left(z - \frac{\pi}{6}\right)^3} dz$, where C is the circle $|z|=1$ (6)

(b) Find the m.g.f. of a random variable whose probability density function is

$$p(X=x) = \begin{cases} \left(\frac{1}{2}\right)^x, & x=1,2,3,\dots \\ 0, & \text{elsewhere} \end{cases}$$

Hence, find the mean and variance. (6)

(c) Verify the Cayley-Hamilton Theorem for matrix A and hence find A^{-1} for

$A = \begin{pmatrix} 1 & 4 \\ 2 & 3 \end{pmatrix}$, Hence, find $A^5 - 4A^4 - 7A^3 + 11A^2 - A - 10I$ in terms of A. (8)

5.(a) Express $p(x) = 7 + 8x + 9x^2$ as a linear combination of $p_1(x) = 2 + x + 4x^2$,
 $p_2(x) = 1 - x + 3x^2$, $p_3(x) = 2 + x + 5x^2$. (6)

(b) Using Cauchy residue theorem, evaluate $\int_0^{2\pi} \frac{\cos 2\theta}{5 + 4 \cos \theta} d\theta$ (6)

(c) In an examination marks obtained by students in mathematics, physics and chemistry are normally distributed with mean 51, 53, 46 and with standard deviation 15, 12, 16 respectively, find the probability of securing total marks (i) 180 or above (ii) 90 or below. (8)

6. (a) If $A = \begin{bmatrix} 1 & 0 & 0 \\ 1 & 0 & 1 \\ 0 & 1 & 0 \end{bmatrix}$, Find A^{50} . (6)

(b) Using Cauchy residue theorem, evaluate $\oint_C \frac{e^z}{(z^2 + \pi^2)^2} dz$, where C is the circle $|z|=4$. (6)

(c) Using Rayleigh-Ritz method, solve the boundary value problem

$I = \int_0^1 \left(xy + \frac{1}{2} y'^2 \right) dx$; $0 \leq x \leq 1$, given $y(0) = y(1) = 0$ where $\bar{y}(x) = c_0 + c_1 x + c_2 x^2$. (8)

SE/IV | choice Based | GATE | 27/11/18

(Time: 3 Hours)

[Total Marks: 80]

- N.B. (1) Question No. 1 is compulsory.
 (2) Solve any **three** questions from remaining **five** questions.
 (3) **Figures** to the right indicate **full marks**.
 (4) Assume suitable data if necessary and mention the same in answer sheet.
1. (a) Draw a neat labelled diagram of Enhancement Type MOSFET and explain its operation. **20**
 (b) Explain RC Coupled Amplifier.
 (c) What is an Oscillator? Explain Basic Principle of an Oscillator.
 (d) Differentiate Class A, Class B and Class C Power Amplifiers.
 2. (a) Design a two stage RC coupled CS – CE Amplifier to meet following specifications: **15**
 $A_v \geq 500$, $S \leq 8$, $R_i \geq 1 \text{ M}\Omega$, $V_{cc} = 6 \text{ V}$.
 Assume the following data: $\beta_{\text{typ}} = 290$, $h_{ie} = 4.5 \text{ k}\Omega$, $g_{m0} = 5000 \mu\text{S}$, $I_{DSS} = 7 \text{ mA}$,
 $r_d = 50 \text{ k}\Omega$, $V_p = -4 \text{ V}$.
 (b) For a 'n' stage cascaded amplifier, show that overall lower 3 dB cut-off frequency is **05**

$$f_{LT} = \frac{f_L}{\sqrt{2^{1/n} - 1}}$$
 3. (a) With the help of neat block diagram, derive expression for R_{if} , R_{of} , G_{mf} for Voltage **10**
 Series Negative Feedback Amplifier. Give significance of the above mentioned parameters.
 (b) Write Short Note on: Darlington Pair Amplifier. **10**
 4. (a) Find the necessary condition for oscillations to occur and frequency of oscillations of **10**
 Colpitts Oscillator. Also, explain its working.
 (b) Draw a neat diagram of Direct Coupled Class A Amplifier and explain its working. **10**
 Hence, find its efficiency.

57446

5. (a) Determine input impedance, output impedance, voltage gain and current gain for the given cascaded amplifier as shown in the figure below: 10

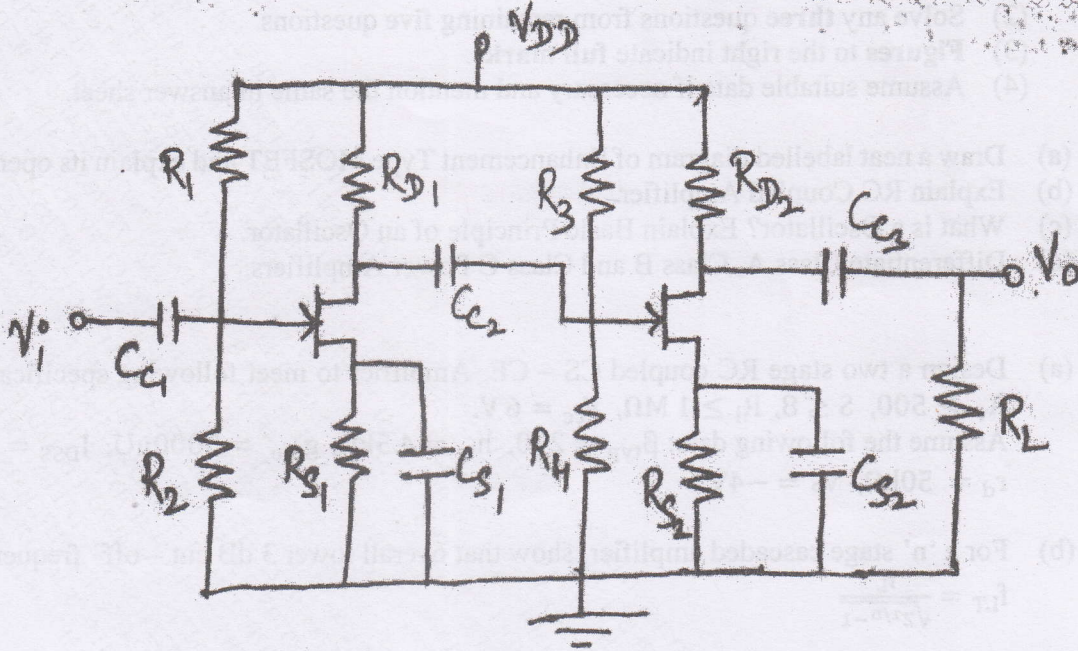

- (b) Draw circuit diagram of Cascode Amplifier and explain in detail. 10

6. (a) State and Explain different types of Biasing techniques for Depletion Type MOSFET. 08

- (b) Explain the concept of Heat Sink in detail required for Power Amplifiers. 07

A Silicon Power Transistor is operated with a heat sink with $Q_{SA} = 1.2^\circ \text{C/W}$. The transistor is rated for 120 W at 25°C and has $Q_{JC} = 0.5^\circ \text{C/W}$. The mounting insulation has $Q_{CS} = 0.5^\circ \text{C/W}$. What maximum power can be dissipated if the ambient temperature is 40°C and $T_{J(\text{max})} = 200^\circ \text{C}$

- (c) Calculate frequency of Oscillation for Hartley Oscillator if $L_1 = L_2 = 1\text{mH}$ and $C = 0.2 \mu\text{F}$. 05

57446

SE, sem-IV, Eled. & Telecomm., Choice base, 5/2018

(Time: 3 Hours)

[Total Marks: 80]

23/12/18

- N.B.:** (1) Question No. 1 is compulsory.
 (2) Solve any three questions from the remaining five.
 (3) Figures to the right indicate full marks.
 (4) Assume suitable data if necessary and mention the same in answer sheet.

- Q.1** Attempt any 4 questions:
- (a) With neat circuit explain the working of comparator circuit. [05]
 (b) Write short note on: Bi FET and Bi MOS differential amplifier circuit. [05]
 (c) Design a circuit with Op Amp, resistors and a capacitor that simulates an inductor of 1 H. [05]
 (d) For a regulated dc power supply the output voltage varies from 12 V to 11.6 V when the load current is varied from 0 to 100 mA which is the maximum value of I_L . If the ac line voltage and temperature are constant, calculate the load regulation, % load regulation and output resistance of the power supply. [05]
 (e) How can the true RMS value of voltage signal to measured using analog multipliers. [05]
- Q.2** (a) Design an adjustable output voltage regulator circuits using IC 317 to give 5 to 12 volts at $I_L=1$ Amp. Given; $I_{ADJ}=100 \mu A$ and let $R_1=240 \Omega$. [10]
 (b) Explain the operation of single slope integrating ADC and state its advantages, disadvantages. [10]
- Q.3** (a) Draw a neat circuit diagram of a RC phase shift oscillator using op-amp. Derive its frequency of oscillation. What are the values of R and C for frequency of oscillation to be 1 kHz? [10]
 (b) Explain the working principle of successive approximation type ADC. [10]
- Q.4** (a) With the help of a neat diagram, input and output waveforms and voltage transfer characteristics explain the working of non-inverting Schmitt trigger. Derive the expressions for its threshold levels. Explain how these levels can be varied? [10]
 (b) Design a differentiator to differentiate an input signal that varies in frequency from 10 Hz to about 500 Hz. Draw its frequency response. If a sine wave of 2 V peak at 500 Hz is applied to the differentiator, write expression for its output and draw output waveform. [10]
- Q.5** (a) Draw the circuit diagram of a square and triangular waveform generator using op-amp. With the help of waveforms at suitable points in the circuit explain its working. Explain how duty cycle can be varied? [10]

58024

- (b) Analyze the circuit given in Fig. 5(b). Draw the waveforms at output terminal v_o and across the capacitor C . Comment on the duty cycle of output waveform. Take diode D as an ideal diode and assume R_A is equal to R_B . [10]

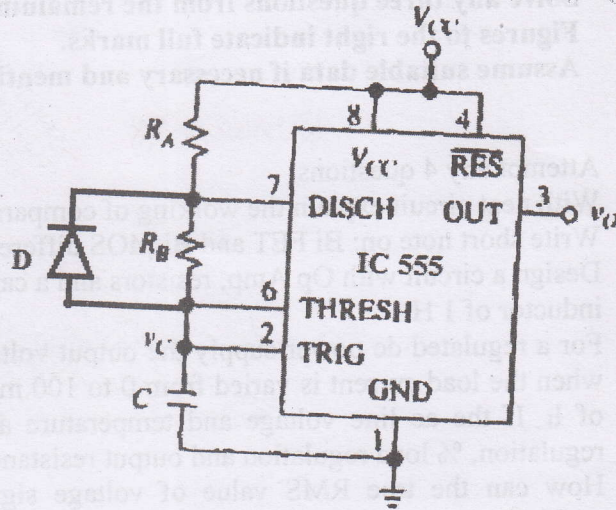

Fig. 5(b)

Q.6 Short notes on: (Attempt any four)

- (a) Wilson current source.
- (b) Temperature compensated log amplifier.
- (c) Wein bridge oscillator.
- (d) XR2206 waveform generator.
- (e) Switch mode power supply.

[05]
[05]
[05]
[05]
[05]

5E, Sem-IV, Electronics & Telecomm., Choice Base

3 Hours

SH2018

Total marks: 80

- Question no. 1 is compulsory
- Attempt any Three questions from remaining

10/12/18

Q1. Answer any 4 questions from the given questions:

20

- Find even and odd part of following continuous time signals
 - $X(t) = 3 + 2t + 5t^2$.
 - $x_2(t) = \sin 2t + \cos t + \sin t \cos 2t$
- Determine energy and power of the unit step signal
- Explain the application of Signals and System in Multimedia Processing.
- Construct the block diagram of discrete time systems whose input output relations are described by following difference equations
 - $Y_1(n) = 0.5x(n) + 0.5x(n-1)$
 - $Y_2(n) = 0.25y_1(n-1) + 0.5x(n) + 0.75x(n-1)$
- Test the given system for linearity, causality, stability, memory and time variant.

$$y(t) = x(t^2)$$

- Give advantages of state space analysis for system analysis

Q2. Perform convolution of $x_1(t) = e^{-3t}u(t)$ and $x_2(t) = tu(t)$ using mathematical method and also by graphical method. 20

Q3.a. Determine the sequence $x[n]$ associated with Z-Transform 10

$$X(z) = \frac{1}{1 - 1.5z^{-1} + 0.5z^{-2}}$$

b. Find the impulse response $h(n)$ of the system if the spectrum is given by 10

$$H(e^{jw}) = \frac{1}{3} (1 + \cos w)$$

Q4.a. Explain the procedure to obtain transfer function of system from state model of the system. 10

~~58047~~

b. Find exponential Fourier series for $x(t)$

10

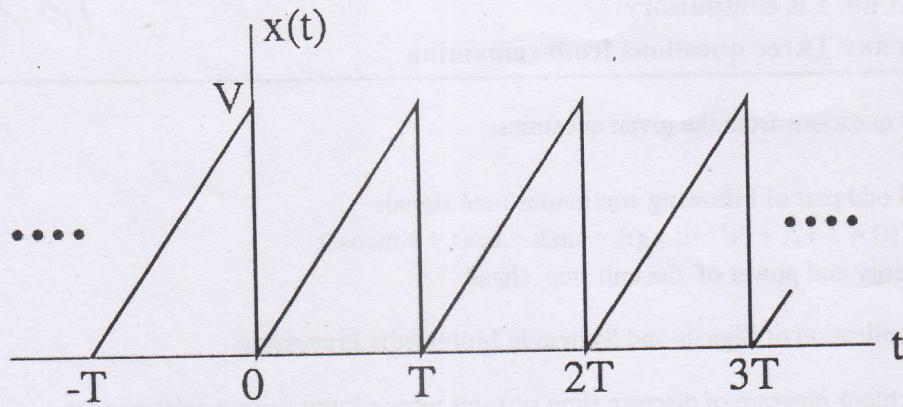

Q5.a Determine Fourier transform of gate function given by $x(t) = A$ for $|t| \leq \frac{\tau}{2}$

8

b. Find Laplace transform of $x(t) = u(t) - u(t - a)$.

4

c. Find Initial and final value using Laplace transform

8

$$X(s) = \frac{7s + 6}{s(3s + 5)}$$

Q6. Write short note on any two:

20

a. Relation of ESD, PSD with auto-correlation

b. ROC in Z-Transform and Laplace Transform

c. Feedforward Control system

SE, sem. IV, Elect. & Telecomm.
(Choice Base) (3 Hours)

Q.P. Code 39182

SHE 018

Total Marks : 80

14/12/18

N.B. (1) Question No. 1 is compulsory.

(2) Attempt any three questions out of remaining five.

(3) Figures to the right indicate full marks.

(4) Assume suitable data if required and mention the same in answer sheet

1. Solve any four

- (a) Modulation Index for AM should be less than one. Justify/Contradict.
- (b) What is aliasing? How it can be prevented?
- (c) Why AGC is required in radio receivers?
- (d) Justify, why FM is more immune to noise?
- (e) Define noise figure and noise factor.

20

2. (a) State and prove sampling theorem for low pass bandlimited signals.

10

(b) One input to AM modulation is 800 KHz carries with an amplitude of 10

10

Vp. The second input is 10KHz modulating signal that is of sufficient amplitude to cause a change in o/p wave of $\pm 5.5Vp$. Determine.

- i) Upper and lower side frequency
- ii) Modulation co-efficient and percent modulation
- iv) Draw o/p frequency spectrum
- v) Draw modulated wave showing maxima and minima of waveforms

3. (a) Explain the operation of Foster seeley discriminator with the help of circuit diagram and phasor diagram.

10

(b) Explain the working of stabilized reactance modulator with suitable diagram.

10

4. (a) With help of neat diagram and waveforms explain generation and demodulation of PWM

10

(b) Explain phase shift method for suppression of unwanted carrier with neat block diagram.

10

5. (a) Explain the following with reference to AM receiver

- (i) Double spotting
- (ii) Three point tracking
- (iii) Image frequency rejection ratio
- (iv) Fidelity

10

(b) Explain Indirect FM transmitter with suitable diagram.

10

6. Write short note on(any four)

20

- (a) Vestigial side band transmission (VSB) and its application.
- (b) μ -law and A-law companding
- (c) Frequency division Multiplexing (FDM)
- (d) Amplitude limiting and thresholding
- (e) Pre emphasis and de-emphasis circuits and its need
