

Dept  
III - Comp  
Rev

SE/III/choice Based/Comp/20/11/18  
Time : 3 hrs

Marks : 80

NB 1. Question No.1 is compulsory

2. Attempt any three from the remaining six questions

3. Figures to the right indicate full marks

Q1a If Laplace transform of  $\text{erf}(\sqrt{t}) = \frac{1}{s\sqrt{s+1}}$ , then find  $L\{e^t \cdot \text{erf}(2\sqrt{t})\}$  [20]

b Find the Orthogonal Trajectory of the family of curves given by  $e^{-x} \cdot \cos y + x \cdot y = c$

c Find Complex Form of Fourier Series for  $e^{2x}$ ;  $0 < x < 2$

d. If the two regression equations are  $5x - 6y + 90 = 0$ ,  $15x - 8y - 180 = 0$ ,

find the means of  $x$  and  $y$ , the Correlation Coefficient and Standard deviation of  $x$  if variance of  $Y$  is 1

Q2 Show that the function is Harmonic and find the Harmonic Conjugate  $v = e^x \cdot \cos y + x^3 - 3xy^2$  [6]

b Find Laplace Transform of  $f(t) = \begin{cases} t & ; 0 < t < 1 \\ 0 & ; 1 < t < 2 \end{cases}$ ,  $f(t+2) = f(t)$  [6]

c. Find Fourier Series expansion of  $f(x) = x - x^2$ ,  $-1 < x < 1$  [8]

Q3 a Find the Analytic function  $f(z) = u + iv$  if  $v = \log(x^2 + y^2) + x - 2y$  [6]

b Find Inverse Z transform of  $\frac{3z^2 - 18z + 26}{(z-2)(z-3)(z-4)}$ ,  $3 < |z| < 4$  [6]

c Solve the Differential Equation  $\frac{d^2y}{dt^2} + 4y = f(t)$ ,  $f(t) = H(t-2)$ ,  $y(0) = 0$ ,  $y'(0) = 1$  using Laplace Transform [8]

Q4 a Find  $Z\{f(k) * g(k)\}$  if  $f(k) = \left(\frac{1}{2}\right)^k$ ,  $g(k) = \cos \pi k$  [6]

b Find the Spearman's Rank correlation coefficient between  $X$  and  $Y$ . [6]

X	60	30	37	30	42	37	55	45
Y	50	25	33	27	40	33	50	42

c Find the inverse Laplace transform of i)  $\frac{3s+1}{(s+1)^4}$  ii)  $\frac{e^{4-3s}}{(s+4)^{5/2}}$  [8]

Q5 a Find Inverse Laplace Transform using Convolution theorem  $\frac{1}{(s-4)^2(s+3)}$  [6]

b Show that the functions  $f_1(x) = 1$ ,  $f_2(x) = x$  are Orthogonal on  $(-1,1)$ . Determine the constants  $a, b$  such that the function  $f(x) = -1 + ax + bx^2$  is Orthogonal to both  $f_1(x), f_2(x)$  on the  $(-1,1)$  [6]

c Find the Laplace transform of i)  $e^{-3t} \int_0^t t \sin 4t dt$  ii)  $\int_0^\infty \frac{e^{-t} - e^{-2t}}{t} dt$  [8]

Q6 a Fit a second degree parabola to the given data [6]

X	1	1.5	2	2.5	3	3.5	4
Y	1.1	1.3	1.6	2	2.7	3.4	4.1

b Find the image of  $\left|z - \frac{5}{2}\right| = \frac{1}{2}$  under the transformation  $w = \frac{3-z}{z-2}$  [6]

c Find Half Range Cosine Series for  $f(x) = x \sin x$  in  $(0, \pi)$  and hence find  $\frac{1}{1.3} - \frac{1}{3.5} + \frac{1}{5.7} - \dots = \frac{\pi-2}{4}$  [8]

\*\*\*\*\*

SE / comp / choice Based / III / 28/11/18

Duration: - 3 Hours

Marks: 80 Marks

NB: - Question 1 is compulsory

Solve any three questions from the remaining.

- 1
  - a) Convert decimal number 576.24 into binary, base-9, octal, hexadecimal system. 04
  - b) Construct hamming code for 1010 using odd parity. 04
  - c) Convert  $(-89)_{10}$  to its equivalent Sign Magnitude, 1's Complement and 2's Complement Form 04
  - d) Perform  $(BC5)_H - (A2B)_H$  without converting to any other base 04
  - e) Prove De Morgans theorem 04
  
- 2a. Given the logic expression:  $A + \overline{BC} + AB\overline{D} + ABCD$  10
  1. Express it in standard SOP form.
  2. Draw K-map and simplify.
  3. Draw logic diagram using NOR gates only.
  
- 2b. Reduce using Quine McClusky method & realize the operation using only NAND gates. 10

$F(A,B,C,D) = \prod M(0, 2, 3, 6, 7, 8, 9, 12, 13)$ .
  
- 3a. Design a 4-bit binary to gray code converter. 10
  
- 3b. Design a 4-bit BCD adder using IC 7483 and necessary gates. 10
  
- 4a. Implement the following logic function using all 4:1 multiplexers with the select inputs as 'B', 'C', 'D', 'E' only. 10

$F(A,B,C,D,E) = \sum m(0, 1, 2, 3, 6, 8, 9, 10, 13, 15, 17, 20, 24, 30)$
  
- 4b. Convert a SR flip flop to JK flip flop 10
  
- 5a. Design a mod-6 synchronous counter using T FF 10
  
- 5b. Explain the operation of 4-bit universal shift register. 10
  
6. Write short notes on any two 20
  - a. VHDL
  - b. TTL and CMOS logic families
  - c. 4-bit Magnitude comparator
  - d. 3 to 8-line decoder

SE, SEM-III, COMPUTER, 5H2018

(Choice base) (3 Hours)

04/11/2018 [Total Marks: 80]

- N.B (1) Question No. 1 is compulsory.  
 (2) Solve any three questions out of remaining five questions.  
 (3) Assumptions made should be clearly stated.  
 (4) Figures to the right indicate full marks.

Q.1 (a) Two dice are rolled, find the probability that the sum is  
 (i) Equal to 1 (ii) Equal to 4 (iii) Less than 13 [6M]

(b) Use the laws of logic to show that  
 $[(p \rightarrow q) \wedge \sim q] \rightarrow \sim p$  is a tautology [6M]

(c) Determine the matrix of the partial order of divisibility on the set A. Draw the Hasse diagram of the Poset. Indicate those which are chains [8M]

- (1)  $A = \{1, 2, 3, 5, 6, 10, 15, 30\}$   
 (2)  $A = \{3, 6, 12, 36, 72\}$

Q.2 (a) Find the complement of each element in  $D_{42}$ . [6M]

(b) Let Q be the set of positive rational numbers which can be expressed in the form  $2^a 3^b$ , where a and b are integers. Prove that algebraic structure  $(Q, \cdot)$  is a group. Where  $\cdot$  is multiplication operation. [6M]

(c) Define isomorphic graphs. Show whether the following graphs are isomorphic or not. [8M]

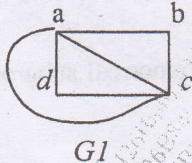

G1  
Fig (a)

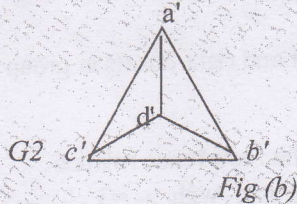

G2  
Fig (b)

Q.3 (a) Determine which of the following graph contains an Eulerian or Hamiltonian circuit. [6M]

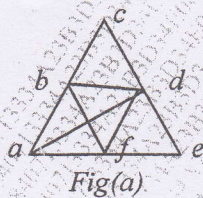

Fig(a)

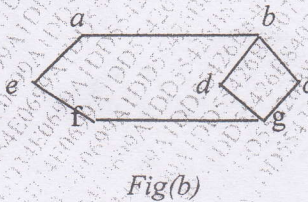

Fig(b)

(b) For all sets A, X and Y show that  
 $A \times (X \cap Y) = (A \times X) \cap (A \times Y)$  [6M]

(c) Let  $f(x) = x+2$ ,  $g(x) = x-2$  and  $h(x) = 3x$  for  $x \in \mathbb{R}$ , Where  $\mathbb{R}$  = Set of real numbers. Find  
 $(g \circ f)$ ,  $(f \circ g)$ ,  $(f \circ f)$ ,  $(g \circ g)$ ,  $(f \circ h)$ ,  $(h \circ g)$ ,  $(h \circ f)$ ,  $(f \circ h \circ g)$  [8M]

Q.4 (a) Let R is a binary relation. Let  $S = \{(a, b) \mid (a, c) \in R \text{ and } (c, b) \in R \text{ for some } c\}$  Show that if R is an equivalence relation then S is also an equivalence relation. [6M]

[TURN OVER

(b) Determine the generating function of the numeric function  $a_r$ , where

- (i)  $a_r = 3^r + 4^{r+1}, r \geq 0$
- (ii)  $a_r = 5, r \geq 0$

[6M]

(c) Consider the (3, 6) encoding function  $e: B^3 \rightarrow B^6$  defined by

- $e(000) = 000000$     $e(001) = 001100$     $e(010) = 010011$     $e(011) = 011111$
- $e(100) = 100101$     $e(101) = 101001$     $e(110) = 110110$     $e(111) = 111010$

[8M]

Decode the following words relative to a maximum likelihood decoding function.

- (i) 000101   (ii) 010101

Q.5 (a) Determine the number of positive integers  $n$  where  $1 \leq n \leq 100$  and  $n$  is not divisible by 2, 3 or 5.

[6M]

(b) Use mathematical induction to show that  $1+5+9+\dots+(4n-3) = n(2n-1)$

[6M]

(c) Find the greatest lower bound and least upper bound of the set  $\{3, 9, 12\}$  and  $\{1, 2, 4, 5, 10\}$  if they exist in the poset  $(Z^+, /)$ . Where  $/$  is the relation of divisibility.

[8M]

Q.6 (a) Let  $A = \{1, 2, 3, 4\}$  and Let  $R = \{(1,1) (1,2) (1,4) (2,4) (3,1) (3,2) (4,2) (4,3) (4,4)\}$ . Find transitive closure by Warshall's algorithm.

[6M]

(b) Let  $H = \{[0]_6, [3]_6\}$  find the left and right cosets in group  $Z_6$ . Is  $H$  a normal subgroup of group of  $Z_6$ .

[6M]

(c) Find the complete solution of the recurrence relation

$$a_n + 2a_{n-1} = n + 3 \text{ for } n \geq 1 \text{ and with } a_0 = 3$$

[8M]

SE, sem III, Computer, SH2018

(3 Hours)

Choice Base

(Total Marks: 80)

- N.B. : 1. Question ONE is compulsory.  
2. Solve any THREE out of remaining questions.  
3. Draw neat and clean diagrams.  
4. Assume suitable data if required.

- Q. 1. A. Explain the concept and significance of CMRR and Slew Rate in case of op-amps. 5  
B. Given  $\beta=120$  and  $I_E= 3.2$  mA for a common-emitter configuration with  $r_0=\infty \Omega$ , determine:  
(a)  $Z_i$   
(b)  $A_v$  if a load of  $2$  k $\Omega$  is applied.  
(c)  $A_i$  with the  $2$  k $\Omega$  load. 5  
C. Discuss the factors that influence modulation index of an FM wave. 5  
D. Justify that adaptive delta modulation superior to delta modulation. 5

- Q. 2 A. The emitter bias configuration as shown in following figure has the specifications:  
 $I_{CQ} = \frac{1}{2} I_{Csat}$      $I_{Csat} = 8$  mA     $V_C = 18$  V    and     $\beta = 110$   
Determine  $R_C$ ,  $R_E$  and  $R_B$ . 10

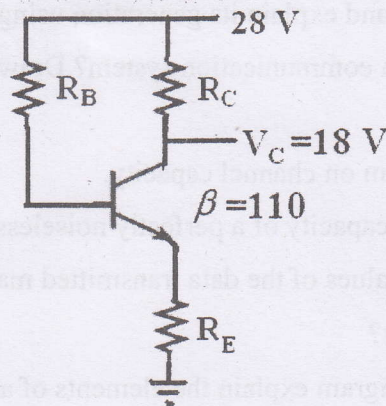

- B. Explain how op-am can be used comparator and zero crossing detector. 10

TURN OVER

Q. 3 A. What is the source of the leakage current in a transistor?

If the emitter current of a transistor is 8 mA and  $I_B$  is  $1/100$  of  $I_C$ , determine the levels of  $I_C$  and  $I_B$ .

5

B. Draw and explain Colpitts oscillator.

5

C. Explain principle of FDM.

5

D. Determine the output voltage for the circuit if  $V_1=5V$  and  $V_2=3V$

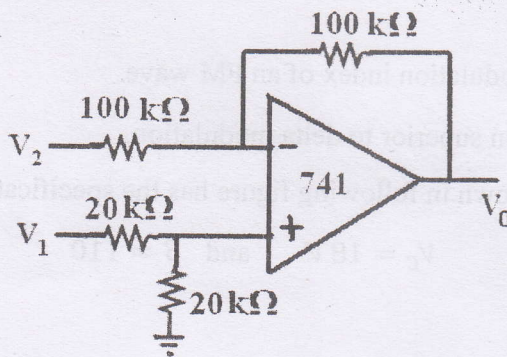

5

Q. 4 A. What is DSBSC wave and explain its generation using balanced modulator.

10

B. What is multiplexing in communication system? Draw block diagram of TDM-PCM system and explain.

10

Q. 5 A. State Shannon's theorem on channel capacity.

What is the maximum capacity of a perfectly noiseless channel whose bandwidth is 120 Hz, in which the values of the data transmitted may be indicated by any one of the 10 different amplitudes?

10

B. With respect to neat diagram explain the elements of analog communication system.

10

Q. 6 A. What is meant by Nyquist rate in sampling and explain its significance.

5

B. Give the proper definition for entropy and information rate.

5

C. Write short note on op-amp as differentiator.

5

D. Differentiate between Class A and Class C power amplifiers with respect to circuit diagram, operating cycle and power efficiency.

5

SE | Comp | III | choice Based | 17/12/18

Q.P. Code: 36286

Duration: 3 Hours

Total Marks: 80

- N.B:
- (1) Question No. 1 is Compulsory
  - (2) Attempt any **three** questions of the remaining **five** questions
  - (3) **Figures** to the **right** indicate **full marks**
  - (4) Make suitable assumptions wherever necessary with proper justifications

1. (a) What are various operations possible on data structures? (05)
- (b) What are different ways of representing a Graph data structure on a computer? (05)
- (c) Describe Tries with an example. (05)
- (d) Write a function in C to implement binary search. (05)

2. (a) Use stack data structure to check well-formedness of parentheses in an algebraic expression. Write C program for the same. (10)

- (b) Given the frequency for the following symbols, compute the Huffman code for each symbol. (10)

Symbol	A	B	C	D	E
Frequency	24	12	10	8	8

3. (a) Write a C program to implement priority queue using arrays. The program should perform the following operations: (12)

- i. Inserting in a priority queue
- ii. Deletion from a queue
- iii. Displaying contents of the queue

- (b) What are expression trees? What are its advantages? Derive the expression tree for the following algebraic expression:  $(a + (b/c)) * ((d/e) - f)$  (08)

4. (a) Write a C program to represent and add two polynomials using linked list. (12)

- (b) How does the Quicksort technique work? Give C function for the same. (08)

5. (a) What is a doubly linked list? Give C representation for the same. (05)

- (b) Given the postorder and inorder traversal of a binary tree, construct the original tree: (10)

Postorder: D E F B G L J K H C A

Inorder: D B F E A G C L J H K

- (c) What is hashing? What properties should a good hash function demonstrate? (05)

6. (a) Given an array  $\text{int } a[] = \{69, 78, 63, 98, 67, 75, 66, 90, 81\}$ . Calculate address of  $a[5]$  if base address is 1600. (02)

- (b) Give C function for Breadth First Search Traversal of a graph. Explain the code with an example. (10)

- (c) Write a C program to implement a singly linked list. The program should be able to perform the following operations: (08)

- (i) Insert a node at the end of the list
- (ii) Deleting a particular element
- (iii) Display the linked list

\*\*\*\*\*