

85) choice Band | ETRX | 13/11/18

Q.P. Code: 53424

Time: 3 hours

Total marks: 80

- N.B. (1) Question No.1 is compulsory.  
 (2) Answer any three questions from remaining.  
 (3) Figures to the right indicate full marks.

Q1.

a) Find the extremal of  $\int_{x_0}^{x_1} \frac{1+y^2}{y^2} dx$  05

b) Evaluate  $\int_C \frac{\sin^2 z}{\left(z - \frac{\pi}{6}\right)^3} dz$ , where C is the circle  $|z|=1$  05

c) If  $A = \begin{bmatrix} \pi & \frac{\pi}{4} \\ 0 & \frac{\pi}{2} \end{bmatrix}$  find  $\cos A$  05

d) The number of messages sent per hour over a computer network has the following probability distribution 05

x	10	11	12	13	14	15
P(X=x)	.08	3k	6k	4k	4k	.07

Find the mean and variance of number of messages sent per hour.

Q2.

a) Construct an Orthonormal Basis of  $R^3$  using Gram Schmidt process to  $S = \{(1, 0, 0), (3, 7, -2), (0, 4, 1)\}$  06

b) Evaluate  $\int_0^{2+i} (z^2 + 1) dz$  along 06

i)  $\frac{z}{2}$   
 ii) The real axis to 2 and then vertically to 2+i

c) i) An underground mine has 5 pumps installed for pumping out storm water. The probability of any one of the pumps failing during the storm is  $\frac{1}{5}$ . What is the probability that at least 2 pumps will be working. 04

ii) Let W be the set of 2x2 matrices of the form  $\begin{bmatrix} a & 0 \\ 0 & b \end{bmatrix}$

04

Show that W is a subspace of space V of all 2x2 matrices

Q3.(a) Calculate Karl Pearson's coefficient of correlation between expenditure and sales from data given

Advertising Expenses ('000 Rs)	39	65	62	90	82	75	25	98	36	78
Sales (Lakhs of Rupees)	47	53	58	86	62	68	60	91	51	84

06

b) Show that the matrix  $A = \begin{bmatrix} -2 & 2 & -3 \\ 2 & 1 & -6 \\ -1 & -2 & 0 \end{bmatrix}$  is derogatory

06

c) Evaluate  $\int_0^{2\pi} \frac{d\theta}{13 + 12 \cos \theta}$

08

Q4.

a) Using Cauchy's Residue Theorem evaluate  $\int_C \frac{\sin \pi z^2 + \cos \pi z^2}{(z-1)^2(z-2)} dz$

06

where C is the circle  $|z| = 3$

b) Find the extremals of the functional  $\int_{x_0}^{x_1} (y'^2 - y^2 + x^2) dx$

06

c) i) Assume that the probability of an individual coal miner being injured in a mine accident during a year is  $\frac{1}{2400}$ . Calculate the probability that in a mine employing 200 miners there will be at least one fatal accident in a year

04

ii) If X denotes the outcome when a fair die is tossed, Find the M.G.F of X about the origin. Hence find the first two moments about the origin.

04

a) The IQ's of army volunteers in a given year are normally distributed with

Q5 mean 110 and standard deviation 10. The army wants to give advanced training to 20% of those recruits with the highest scores. What is the lowest IQ score acceptable for advanced training. 06

b) Solve by Rayleigh Ritz method the boundary value problem

$$I = \int_0^1 (y'^2 - y^2 - 2xy) dx \quad \text{given } y(0)=0 \text{ and } y(1)=0 \quad 06$$

c) Show that the matrix  $A = \begin{bmatrix} 11 & -4 & -7 \\ 7 & -2 & -5 \\ 10 & -4 & -6 \end{bmatrix}$  is similar to a diagonal matrix. 08

Find the transforming matrix and the diagonal matrix.

Q6. (a) Verify Cayley Hamilton Theorem for  $A = \begin{bmatrix} 4 & 3 & 1 \\ 2 & 1 & -2 \\ 1 & 2 & 1 \end{bmatrix}$  06

Hence find  $A^{-1}$

(b) Obtain Taylor's and Laurent's series expression for  $f(z) = \frac{z-1}{(z^2-2z-3)}$  06  
indicating region of convergence.

(c) i) The lines of regression of bivariate population are  $8x-10y+66=0$  and  $40x-18y=214$ . The variance of x is 9.

Find

- a) coefficient of correlation r
- b) the standard deviation of y 04

ii) If a, b, c are three positive numbers then using Cauchy Schwarz inequality prove that  $(a+b+c) \left( \frac{1}{a} + \frac{1}{b} + \frac{1}{c} \right) \geq 3^2$  04

\*\*\*\*\*

SE (IV) choice Based | ETR | 27/11/18

Q.P. Code :37284

[Time: 3 Hours]

[Marks: 80]

Please check whether you have got the right question paper.

- N.B:**
1. **Q.1 is compulsory.**
  2. Solve **any three** questions from **Q.2 to Q.6**
  3. Assume suitable data

1. Write any **four** 20
  - (a) Explain high frequency equivalent circuit of BJT.
  - (b) Explain Barkhausen criteria
  - (c) Draw MOSFET differential amplifier with active load.
  - (d) Calculate max. power dissipation with and without heat sink  
 $\theta_{JC} = 1.75^\circ \text{ C/W}$ ,  $\theta_{CS} = 1^\circ \text{ C/W}$ ,  $\theta_{CA} = 50^\circ \text{ C/W}$   
 $\theta_{SA} = 5^\circ \text{ C/W}$ ,  $T_{JMAX} = 150^\circ \text{ C}$  and  $T_{AMB} = 30^\circ \text{ C}$
  - (e) Explain PNP diode.
2.
  - (a) Explain class B push pull power amplifier and cross over distortion also derive expression for efficiency. 10
  - (b) Explain small signal analysis for MOSFET active load circuit 10
3. (a) Calculate lower cut off frequency for given circuit. 10  
 $\beta = 80$ ,  $r_\pi = 1.3 \text{ K}\Omega$ ,  $g_{m2} = 50 \mu \text{ A/V}$ ,  $C_\pi = 15 \text{ pF}$ ,  $C_\mu = 1 \text{ pF}$

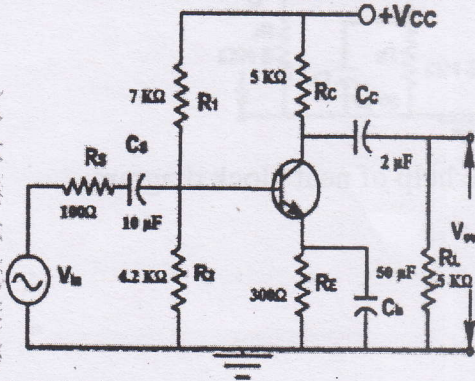

- (b) Explain working of SCR with V-I characteristics and its applications. 10
4. (a) Explain Hartley oscillator. Design the same for 50KHz. 10

Turn Over

Q.P. Code :37284

(b) Find  $I_Q$  for given circuit.

$K_{n1} = K_{n2} = 0.1 \text{ mA/V}^2$ ,  $K_{n3} = K_{n4} = 0.3 \text{ mA/V}^2$ ,  $V_{TN} = 1 \text{ V}$ ,  
 $\lambda = 0$  for  $M_1, M_2, M_3$  and  $\lambda = 0.01/\text{V}$  for  $M_4$

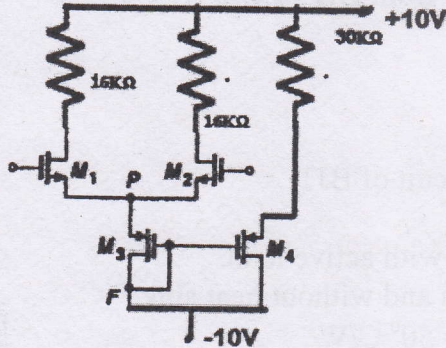

10

5. (a) Calculate bandwidth for two stage RC coupled CE amplifier.

$\beta_1 = 100$ ,  $\beta_2 = 150$ ,  $r_{\pi 1} = r_{\pi 2} = 1.3 \text{ K}\Omega$ ,  $g_{m1} = g_{m2} = 50 \text{ mA/V}$   
 $C_{\pi 1} = C_{\pi 2} = 15 \text{ pF}$ ,  $C_{\mu 1} = C_{\mu 2} = 1 \text{ pF}$

10

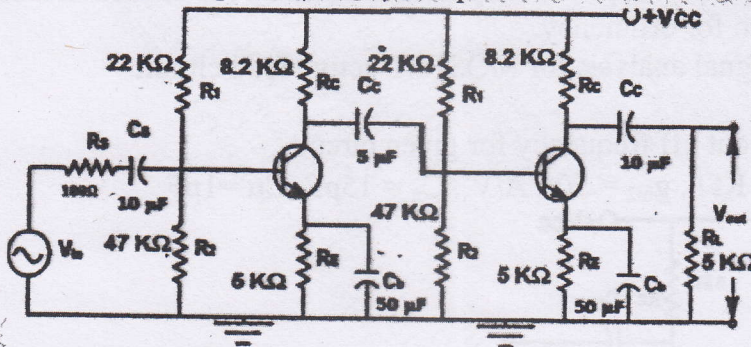

(b) Explain feedback topologies with the help of neat block diagram.

10

6. Solve any three

20

- (a) Cascode MOSFET amplifier
- (b) UJT relaxation oscillator
- (c) Darlington configuration
- (d) Power BJTs

Turn Over

SE, SEM IV, ELECTRONICS, SH2018

03/12/18

[Max Marks 80]

(Choice base)

[Time: 3 hours]

- 1) Question no. 1 is compulsory
- 2) Solve any three from the remaining five questions.
- 3) Assume suitable additional data if necessary.

Q1) Answer the following questions:

- a) Explain the significance of HOLD, RESET and READY signals in 8086 processor
- b) List the steps taken by 8086 processor in response to receiving an interrupt.
- c) Draw the 8086-8087 interfacing circuit representation in maximum mode of operation.
- d) Explain the use & advantage of pipelining feature in 8086 architecture.

(20)

Q2) a) List and explain with examples memory addressing modes in 8086 processor.

(10)

b) Explain the register structure of 8086 processor.

(10)

Q3) a) With the help of memory map interface the following to an 8086 based system operating in minimum mode:

(10)

- i) 32K bytes of EPROM memory using 8k byte devices.
- ii) 32K bytes of RAM memory using 8k byte devices.

b) Classify and explain 8086 instruction set.

(10)

Q4) a) Explain the significance of flags and flag register of 8086 processor.

(10)

b) Explain the need for DMA and modes of DMA data transfer typically made use of by the DMA controller IC - 8237.

(10)

Q5) a) Explain the Intel Pentium processor's pipelining and superscalar architecture.

(10)

b) With the help of a neat flowchart/algorithm write a program in 8086 assembly to copy an array of 100 numbers initialised in the data segment to extra segment. Assume additional data if any.

(10)

Q6) Write short notes on: [ANY TWO]

a) Programmable interrupt controller – 8259.

(10)

b) Intel Pentium processor – Branch Prediction Logic

(10)

c) Programmable peripheral interface – 8255.

(10)

d) INT 21H – DOS interrupt.

(10)

SE, sem-IV, Electronics, Choice Base, SH 2018

(Time: 3 Hours)

Max Mrks:80

10/12/18

- N.B:1) Question no. 1 is compulsory.  
 2) Attempt any three out of the remaining five questions.  
 3) Use suitable data, wherever necessary.

Q1. Attempt the following questions.

- (A) Differentiate between Mealy and Moore machine. (5)
- (B) Draw the Standard symbols for ASM Charts. (5)
- (C) Differentiate between signal and Variable. (5)
- (D) Explain what Entity in VHDL is. (5)

Q2. (A) Analyze the clocked synchronous machine given below. Write excitation equations, transition table and state/output table. Also draw the state diagram. (10)

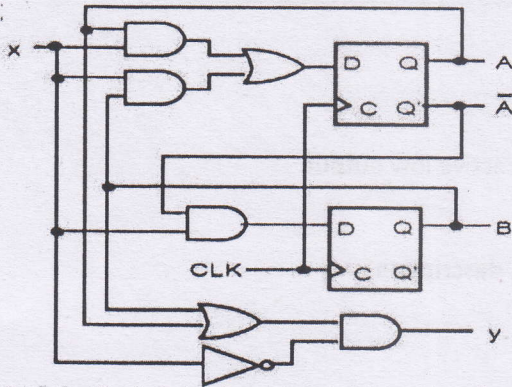

(B) Design a mealy sequence detector to detect a sequence 1101 using D flip-flops and logic gates. (10)

Q3. (A) Design a counter which counts the count from 3 to 12 using IC 74163. (10)  
 (B) Design MOD-12 Counter using IC 7493 and logic gates. (10)

Q4. (A) Design a circuit with optimum utilization of PLA to implement the following functions. (10)

$$F1 = \sum m(0,2,5,8,9,11)$$

$$F2 = \sum m(1,3,8,10,13,15)$$

$$F3 = \sum m(0,1,5,7,9,12,14)$$

58396

B) Eliminate redundant states and draw reduced state diagram. (10)

PS	NS		Out Put Y
	X=0	X=1	
A	B	C	1
B	D	F	1
C	F	E	0
D	B	G	1
E	F	G	0
F	E	D	0
G	F	G	0

Q5. (A) Write a VHDL code for JK flip-flop. (10)

(B) Write a VHDL code for 3:8 decoder with active low output. (10)

Q6. (A) Write a note on CPLD. (10)

(B) Draw the data unit for the following RTL description (10)

Module; Data Mover

Memory: A[2]; B[2]; C[2].

Inputs : X[2].

Outputs : Z[2].

1.  $A \leftarrow X$ .
2.  $C \leftarrow \bar{A}$ .
3.  $B \leftarrow C[0], C[1]$ .
4.  $C \leftarrow A \vee B$ .
5.  $Z = C$ .



Lib

SE, Som TV, Electronics, SH2018

14/12/18

(Choice Base) (3 Hours)

[Total Marks:80]

- N. B.: 1) Question No. 1 is compulsory.  
 2) Attempt any three questions out of the remaining five questions.  
 3) Assume suitable data wherever necessary.

1. Answer the following (any four): 20
  - a) Explain how quantization helps in noise removal.
  - b) Explain why the local oscillator frequency is always chosen as  $f_s + f_{IF}$  and not  $f_s - f_{IF}$ ?
  - c) Explain noise triangle in FM.
  - d) Determine the overall noise factor and noise figure for three cascade amplifiers with the following parameters:  
 $A_1=6dB, A_2=15dB, A_3=10dB$   
 $NF_1=10dB, NF_2=6dB, NF_3=10dB$
  - e) Calculate percentage saving in AM modulated wave to a depth of 100 percent when the carrier and one of the sidebands are suppressed. Compare AM with SSB-SC.
  
2. a) With the help of a neat block diagram explain the FM transmitter using Armstrong method of FM generation. 5  
 b) In a super-heterodyne receiver having no RF amplifier, the loaded Q of the antenna coupling circuit is 100. If the IF is 455kHz, calculate: 1) The image frequency and its rejection ratio for the tuning at 1044kHz. 2) The image frequency and its rejection ratio for the tuning at 30MHz. 5  
 c) With a neat block diagram explain the working of super-heterodyne receiver, with waveforms at the output of each block. Explain the functions of each block. 10
  
3. a) Explain the terms with reference to Radio Receivers: Selectivity, Sensitivity, Fidelity, AGC and Double spotting. 10  
 b) Explain the frequency discriminators with the help of neat diagrams. 10
  
4. a) Explain PAM, PWM and PPM generation with relevant waveforms. 10  
 b) Explain natural sampling and flat top sampling. What is aliasing error? How it can be overcome? 10
  
5. a) Derive the expression for the signal to quantization noise ratio in PCM. 5  
 b) In an FM system, when the audio frequency is 400Hz and the AF voltage is 4V, the deviation is 4.8kHz. Calculate the modulation index and the bandwidth required. If the modulating frequency is halved, what is the new bandwidth? 5  
 c) Explain the working of Delta Modulation with a neat block diagram and showing proper waveforms. 10
  
6. a) Explain FDM with a neat block diagram. Give its applications. 10  
 b) Draw block diagram of PCM transmitter and receiver and explain the function of each block. 10

\*\*\*\*\*

- N.B. (1) Question number 1 is compulsory.  
(2) Attempt any 3 questions from remaining.  
(3) Assume suitable data if required.  
(4) Figure to the right indicates full marks.

Q1. Attempt any four questions in Q1. [20]

- a) Explain lead and lag compensator.
- b) What are the properties of state transition matrix?
- c) Explain Controllability and Observability with necessary condition for stability.
- d) Explain Mason Gains' Formula with its need.
- e) Explain the effect of addition of pole and zero to a system.

Q2. A) Find the transfer function  $C(s)/R(s)$  of the following system using block diagram technique.

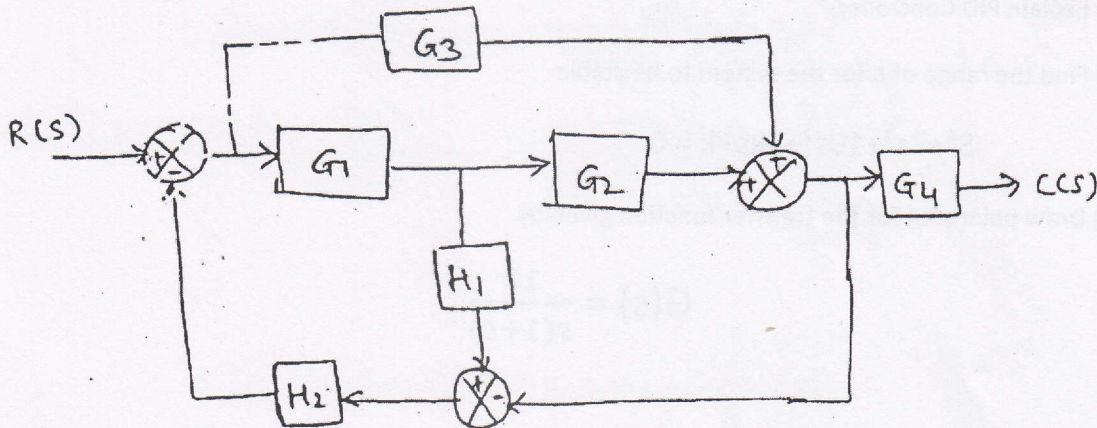

[10]

Q2. B) Consider Unity feedback control system with open loop transfer function given as

[10]

$$G(s)H(s) = \frac{k(s+1)(s+2)}{(s+3)(s-3)}$$

Plot the Root Locus and find the gain at which system is critically damped.

Q3. A) Write a note on advances in control system.

[10]

Q3. B) Obtain the state variable model of the transfer function -

[10]

$$\frac{Y(s)}{R(s)} = \frac{3s + 4}{s^2 + 4s + 3}$$

TURN OVER

Q4. A) Check controllability and observability for the system described by

[10]

$$\dot{x} = \begin{bmatrix} 0 & 6 & -5 \\ 1 & 0 & 2 \\ 3 & 2 & 4 \end{bmatrix} x + \begin{bmatrix} 0 \\ 1 \\ 2 \end{bmatrix} u$$

$$Y = [1 \quad 2 \quad 3] x$$

Q4. B) Determine the stability of the system having characteristic equation

[10]

$$s^8 + 5s^6 + 2s^4 + 3s^2 + 1 = 0$$

Q5. A) Construct the Bode Plot for the following transfer function. Comment on stability.

[10]

$$G(s)H(s) = \frac{10}{s(s+1)(s+5)}$$

Q5. B) List the performance specifications of Time Response Analysis and derive any four of them.

[10]

Q6. A) Explain Adaptive Control System.

[20]

Q6. B) Explain PID Controller.

Q6. C) Find the range of K for the system to be stable

$$S^4 + 7s^3 + 10s^2 + 2ks + k = 0.$$

Q6. D) Draw polar plot for the transfer function given by

$$G(s) = \frac{12}{s(1+s)}$$